

**AN ORDINANCE TO AUTHORIZE CITY CONTRACT  
16010PW - SEWER CONSTRUCTION - WITH BRANDYWINE  
CONSTRUCTION CO., INC.**

---

#4076

Sponsor:

Council  
Member  
Shabazz

**WHEREAS**, pursuant to Section 2-308 and Section 8-200 of the City Charter, the City of Wilmington is authorized to enter into contracts for the supply of property or the rendering of services for more than a period of one year if approved by City Council by Ordinance; and

**WHEREAS**, the City desires to obtain construction and repair services for the City's sewer system; and

**WHEREAS**, the City publicly bid Contract 16010PW - Sewer Construction ("the Contract") - in accordance with Section 8-200 of the City Charter, and subsequently awarded the Contract to Brandywine Construction Co., Inc. ("the Contractor"), the lowest responsible bidder; and

**WHEREAS**, the term of the Contract is for a period of one (1) year beginning on or about July 1, 2015, at a total cost of Nine Hundred Ninety Eight Thousand Ninety Dollars (\$998,090.00), with the possibility of two (2) one-year extensions at the option of the City, subject to a price escalation not to exceed two percent of the original contract cost; and

**WHEREAS**, it is the recommendation of the Department of Public Works that the City enter into the Contract with the Contractor, a copy of which is attached hereto and incorporated by reference as Exhibit "A."

**THE COUNCIL OF THE CITY OF WILMINGTON HEREBY  
ORDAINS:**

**SECTION 1.** Contract 16010PW - Sewer Construction - between the City and Brandywine Construction Co., Inc., a copy of which Contract is attached hereto as Exhibit "A,"

for a period of one (1) year beginning on or about July 1, 2015, at a total cost of Nine Hundred Ninety Eight Thousand Ninety Dollars (\$998,090.00), with the possibility of two (2) one-year extensions at the option of the City, subject to a price escalation not to exceed two percent of the original contract cost, is hereby approved, and the Mayor and the City Clerk are hereby authorized and directed to execute as many copies of said Agreement, as well as all additional undertakings related thereto, as may be necessary.

**SECTION 2.** This Ordinance shall be effective upon its passage by City Council and approval of the Mayor.

First Reading ..... July 2, 2015  
Second Reading..... July 2, 2015  
Third Reading ..... August 27, 2015

Passed by City Council,  
August 27, 2015

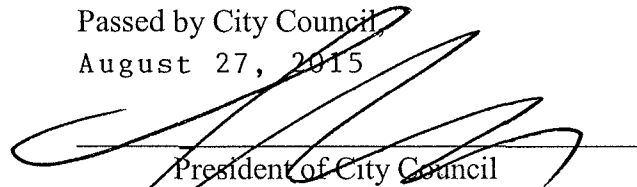
  
\_\_\_\_\_  
President of City Council

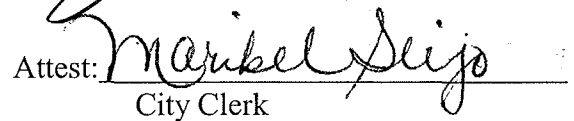
Attest:   
\_\_\_\_\_  
City Clerk

Approved as to form this  
1<sup>st</sup> of July, 2015

  
\_\_\_\_\_  
First Assistant City Solicitor

Approved this 1 day of Sept, 2015.

  
\_\_\_\_\_  
Mayor

**Synopsis:** This Ordinance authorizes the City to enter into Contract 16010PW - Sewer

Construction - with Brandywine Construction Co., Inc., for a period of one (1) year at a total cost of Nine Hundred Ninety Eight Thousand Ninety Dollars (\$998,090.00), with the possibility of two (2) one-year extensions at the option of the City, subject to a price escalation not to exceed two percent of the original contract cost.

## **Agenda**

### **Impact Statement**

This Ordinance authorizes the City to enter into Contract 16010PW - Sewer Construction - with Brandywine Construction Co., Inc., for a period of one (1) year at a total cost of Nine Hundred Ninety Eight Thousand Ninety Dollars (\$998,090.00), with the possibility of two (2) one-year extensions at the option of the City, subject to a price escalation not to exceed two percent of the original contract cost.

CITY CONTRACT 16010PW  
SEWER MAINTEN-ANCE  
BETWEEN  
CITY OF WILMINGTON  
AND  
BRANDYWINE CONSTRUCTION CO., INC (BCCI)

EXHIBIT "A"



Classified Ad Receipt  
(For Info Only - NOT A BILL)

**Customer:** SD CITY WILM PURCHASING DIV  
**Address:** 800 N FRENCH ST FL 5  
WILMINGTON DE 19801  
USA

**Ad No.:** 0000359827  
**Pymt Method:** Invoice  
**Net Amt:** \$170.24

**Run Times:** 2

**No. of Affidavits:** 1

**Run Dates:** 03/24/15, 03/31/15

**Text of Ad:**

The City of Wilmington will receive sealed bids at the Division of Procurement & Records, 5th Fl., Louis L. Redding Bldg., 800 French St., Wilm., DE 19801 for:

16010PW – SEWER MAINTENANCE  
16011WD – WATER DISTRIBUTION SYSTEM MAINTENANCE

Pre-Bid Meeting: Tuesday, April 7, 2015, at 11:00 a.m., in the Turner Conference Room, 6th Floor, Louis L. Redding City/County Building, 800 French Street, Wilmington, DE 19801

Bid opening: Tuesday, April 21, 2015, at 3:00 p.m., in the 5th Floor Finance Conference Room, Louis L. Redding City/County Building, 800 French Street, Wilmington, DE 19801. Specifications may be obtained at the above address for the Division of Procurement & Records.

Philip Ceresini  
Purchasing Agent II  
Division of Procurement and Records

Department of Finance  
pceresini@wilmingtonde.gov  
www.wilmingtonde.gov  
3/2431-NJ

0000359827-01

## INSTRUCTIONS TO BIDDERS

Bids on **City Contract 16010PW – SEWER MAINTENANCE** will be publicly opened and read aloud in the 5<sup>th</sup> Floor Finance Conference Room, Louis L. Redding City/County Building, 800 French Street, Wilmington, DE 19801 on **TUESDAY, APRIL 21, 2015, AT 3:00 p.m.**

2. Proposals must be in triplicate, sealed in an envelope, and the envelope endorsed "**Bid for City Contract 16010PW – SEWER MAINTENANCE**" and addressed to the Department of Finance, Division of Procurement and Records, 5<sup>th</sup> Floor, Louis L. Redding City/County Building, 800 French Street, Wilmington, Delaware.
3. Any bid may be withdrawn prior to the schedule time for opening of bids or authorized postponement thereof. No bid may be withdrawn within thirty (30) calendar days after the actual opening thereof.
4. The successful bidder will be required to have or obtain an appropriate business license from the Department of Finance, Revenue Division, City of Wilmington, in order to be awarded the contract. Before obtaining a City of Wilmington Business License, all applicants must show proof of a current State of Delaware Business License.
5. The corporation, the successful bidder shall furnish a certificate from the State where it is incorporated, stating that it is a subsisting corporation. The corporation shall also furnish one (1) original and two (2) copies of the excerpts of the corporate minutes, which grant authority to those who sign and attest the contract. The Corporate Seal shall be affixed where signatures are attested.
6. The successful bidder will be required to withhold City of Wilmington Wage Tax from their employees and withheld taxes paid to the City of Wilmington pursuant to the provisions of the Wilmington Wage Tax Law. This law applies to people living and/or working in the City of Wilmington.

The U.S. Department of Commerce monitors Procurement transaction made to minority business enterprises by the City of Wilmington. The Minority Business Developments Agency's District Office reserves the right to contact the successful minority bidder and/or subcontractor to confirm any participation in the Procurement process.

8. The successful bidder certifies that they are not listed on the Federal Government, Excluded Parties List System ([www.sam.gov](http://www.sam.gov)). This will be verified by the City of Wilmington and if listed may be grounds for rejection of the bid or proposal.

9. Any person doing business or seeking to do business with the City shall abide by the following Global Sullivan Principles:

- A. Support universal human rights and particularly, those of employees, the communities within which you operate, and parties with whom you do business.
- B. Promote equal opportunity for employees at all levels of the company with respect to issues such as color, race, gender, age, ethnicity, or religious beliefs, and operate without unacceptable worker treatment such as the exploitation of children, physical punishment, female abuse, involuntary servitude, or other forms of abuse.
- C. Respect employee's voluntary freedom of association.
- D. Compensate employees to enable them to meet at least their basic needs and provide the opportunity to improve their skill and capability in order to raise their social and economic opportunities.

**16010PW**

**SEWER CONSTRUCTION**

**Prepared by:**

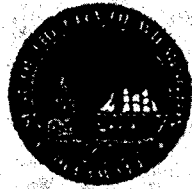

**City of Wilmington, DE  
Department of Public Works  
Water Division  
Louis L. Redding City/County Building  
800 North French Street – 6<sup>th</sup> Floor  
Wilmington, DE 19801**

**February 24, 2015**



# CITY OF WILMINGTON



## GENERAL CONDITIONS FOR CONSTRUCTION CONTRACTS

## INDEX

	<u>PAGE</u>
ACCESS TO WORK.....	GC-14
ALTERATION OF PLANS OR OF CHARACTER OF WORK.....	GC-17
ANNULMENT OF CONTRACT .....	GC-8
AUTHORITY AND DUTIES OF INSPECTORS .....	GC-7
AUTHORITY OF ENGINEER .....	GC-7
AVAILABILITY OF FUNDING .....	BP-5
AWARD AND EXECUTION OF CONTRACT .....	BP-5
AWARD AS AN ENTIRETY .....	BP-4
CLAIMS TO BE MADE PROMPTLY .....	GC-11
CLEANING UP .....	GC-8
COMMENCEMENT OF WORK.....	BP-4
COMPENSATION AND LIABILITY INSURANCE.....	GC-1
CONDITIONAL ACCEPTANCE.....	GC-12
CONTRACTOR'S EXPENSE .....	GC-13
CONTRACTOR'S RESPONSIBILITY FOR WORK .....	GC-6
COOPERATION OF CONTRACTOR AND REPRESENTATIVE .....	GC-5
DAMAGE TO UTILITIES .....	GC-6
DEFECTIVE MATERIALS AND WORK.....	GC-7
DEFINITIONS OF TERMS .....	BP-1
DELINQUENT TAXES, ETC.....	GC-18
DELIVERY AND OPENING OF PROPOSALS .....	BP-3
DIMENSIONS AND LEVELS .....	GC-18
EMPLOYEES AND EQUIPMENT.....	GC-4
ENGINEER MAY INCREASE OR DECREASE QUANTITIES .....	GC-2
ESTIMATED QUANTITIES.....	BP-1
EXECUTION OF CONTRACT .....	BP-4
EXTENSION OF TIME .....	GC-4
EXTRA WORK .....	GC-2
EXTRA WORK A PART OF THE CONTRACT.....	GC-11
FAILURE TO EXECUTE CONTRACT .....	BP-4
FAILURE TO REMOVE AND RENEW DEFECTIVE MATERIALS AND WORK .....	GC-8
FAMILIARITY WITH LAWS, ETC. ....	BP-2
FAMILIARITY WITH PROPOSED WORK .....	BP-2
FINAL ACCEPTANCE OF PAYMENT .....	GC-12
FORCE ACCOUNT WORK .....	GC-3
GUARANTEE .....	GC-14
HOURS OF LABOR .....	GC-14
INDEMNIFICATION OF THE CITY .....	GC-1
INSPECTION OF MATERIALS AND WORK.....	GC-7
INTERPRETATIONS OF ADDENDUM .....	BP-3
INTERPRETATION OF PLANS, ETC.....	GC-17
IRREGULAR PROPOSALS.....	BP-2
LAST PAYMENT TO TERMINATE LIABILITY OF THE OWNER.....	GC-13
LAWS TO BE OBSERVED.....	GC-5

PAGE

LEGAL ADDRESS.....	GC-13
LIABILITY OF CONTRACTOR.....	GC-1
MAINTENANCE OF TRAFFIC.....	GC-6
MAINTENANCE, REPAIRS, ETC., AFTER COMPLETION.....	GC-18
MATERIAL SAMPLES.....	BP-4
MATERIALS AND WORK NOT PAID FOR BY THE CONTRACTOR.....	GC-9
MEASUREMENT OF QUANTITIES.....	GC-9
NIGHT, WEEKEND, AND CITY HOLIDAY WORK.....	GC-13
NO ESTOPPEL OR WAIVER OF LEGAL RIGHTS.....	GC-10
NO LIMITATION OF LIABILITY.....	GC-13
PARTIAL PAYMENT.....	GC-12
PATENTS.....	GC-2
PAYMENTS MAY BE WITHHELD.....	GC-12
PERMITS, LICENSES, CHARGES, AND NOTICES.....	GC-2
PLANS AND SPECIFICATIONS FURNISHED TO CONTRACTOR.....	GC-17
PLANS, ETC., TO BE FOLLOWED.....	GC-17
PROPOSAL FORM.....	BP-2
PROSECUTION OF WORK.....	GC-4
PUBLIC CONVENIENCE AND SAFETY.....	GC-5
QUALIFICATIONS FOR BIDDERS.....	BP-3
QUALITY OF MATERIALS AND WORKMANSHIP.....	GC-18
REMEDIES CUMULATIVE.....	GC-13
RIGHT TO REJECT BIDS.....	BP-3
SANITARY PROVISIONS.....	GC-5
SCOPE OF PAYMENT.....	GC-11
SCOPE OF WORK.....	GC-2
STORAGE OF MATERIALS.....	GC-18
STRIKES, ETC.....	GC-14
SUBCONTRACTORS.....	GC-10
SUPERVISION BY ENGINEER.....	GC-7
TEMPORARY SUSPENSION OF WORK.....	GC-8
TEST OF SAMPLES OF MATERIALS.....	GC-17
UNAUTHORIZED WORK.....	GC-4
UNRESPONSIVE OR UNBALANCED BIDS.....	BP-2
WAGES PAYABLE UNDER MUNICIPAL CONTRACTS, ETC.....	GC-15
WATER SUPPLY.....	GC-5
WITHDRAWAL OF PROPOSALS.....	BP-3

**ATTACHMENTS**

**CITY OF WILMINGTON – DBE PROGRAM AND BIDDERS REQUIREMENTS**

Mayor's Office of Economic Development – SMBEO/DBE Office 1/2010..... 1 - 12

# Construction Contracts

## Bidding Procedures

### DEFINITIONS OF TERMS

Whenever in these specifications and other contract documents the following terms or pronouns in place of them are used, their intent and meaning shall be interpreted as follows:

"City"	The City of Wilmington
"Owner"	The City of Wilmington
"Director"	The Director or Commissioner of the Department of the "City" for which the work is being done or his duly authorized representative.
"Manager"	The Manager, Department of Finance, Division of Procurement and Records.
"Contractor"	Party of the second part of the contract, acting directly or through his agents or employees.
"Work"	Any or all things agreed to be furnished or done by or on the part of the Contractor, and which are required in the construction and completion of the project herein contemplated, including also labor, materials and equipment.
"Engineer"	The City Engineer or his duly authorized representative.

All things contained or referred to herein, the Advertisement, the Instructions to Bidders, the General Conditions, the Special Provisions, the Specifications, the Proposal, the Contract, the Plans, Addenda, as well as any other papers or bulletins referred to therein are hereby made a part of these specifications and contract, and are to be considered as one instrument constituting the "Contract Documents." The intent is to make them explanatory one or to the other but in the case of any inconsistency, the provisions of the Contract shall govern.

Whenever in these contract documents, the words "directed," "required," "prescribed," "permitted," "approved," "acceptable," "in the judgment of," and other words and phrases of like import, refer to the work or its performance, they shall be taken to mean and intend "directed," "required," "prescribed," "permitted," "approved," "acceptable," "in the judgment of," and the like by or to the Director.

The headings and subheadings printed in these specifications are intended for convenience or reference only and shall not be considered as having any particular bearing on the interpretation thereof.

### ESTIMATED QUANTITIES

Any estimates of quantities herein furnished by the Director are approximate only, and have been used by the Director as a basis of estimating the cost of the work, and will also be used for the purpose of tabulating and comparing the bids and awarding the contract. The Engineer has endeavored to estimate these quantities correctly, according to his knowledge and the information shown on the plans;

but it is not guaranteed that these estimated quantities are accurate, and if the Contractor, in making up and/or submitting his bid or bids, relies upon the accuracy of such estimated quantities, he does so at his own risk.

### PROPOSAL FORM

The Bidder will be furnished -- by the Manager -- with proposal forms which will show the approximate estimate of the various quantities of work to be performed and materials to be furnished under the unit and lump sum price items.

The Bidder shall submit his proposal on the forms furnished by the Manager. The blank spaces in the proposal shall be filled in correctly where indicated, for each and every item, and the Bidder shall state the prices (written in ink, in words and numerals) for which he proposes to do each item of the work contemplated. In case of discrepancy between the written figures and the numerals, the written figures shall govern.

The Bidder shall sign his proposal correctly. If the proposal is made by an **individual**, his name and post office address shall be shown. If made by a **firm or partnership**, the name and post office address of the firm or partnership, and of each member thereof, shall be shown. If a **corporation**, the successful bidder shall furnish a certificate from the Secretary of State or commonwealth where the firm is incorporated stating the company is a presently subsisting corporation of that state or commonwealth and the date of its incorporation.

Further, the successful bidder shall furnish an original and two copies of excerpts from the minutes of the corporation authorizing its President or Vice President to execute the necessary Contract on behalf of the Corporation, and an original and two copies of the resolution authorizing the Secretary or the Assistant Secretary to attest Contract Documents and the names of all officers qualified to sign for your company.

### IRREGULAR PROPOSALS

Proposals may be rejected if they show any omissions, alterations of form, additions not called for, conditional or alternative bides, or irregularities of any kind.

### UNRESPONSIVE OR UNBALANCED BIDS

To better insure fair competition, and to permit a determination of the lowest bidder, unresponsive bids or bids obviously unbalanced, may be rejected by the Manager.

### FAMILIARITY WITH PROPOSED WORK

The Bidder is required to examine carefully the site of the work, the proposal, the plans, specifications and other contract documents for the work contemplated and it will be assumed that he had familiarized and satisfied himself as to the conditions and obstacles to be encountered, as to the character, quality and quantities of work to be performed and materials to be furnished, and as to the requirements of these specifications, plans and other contract documents and he must be prepared to execute a finished job in every particular, without any extra charge whatever, except as may be specifically provided for elsewhere in these contract documents.

### FAMILIARITY WITH LAWS, ETC.

The Bidder is assumed to have made himself familiar with all Federal, State, Local, and municipal laws, ordinances, rules and regulations which in any manner affect those engaged or employed in the work, or the materials or equipment used in or upon the work, or in any way affect the work, and no plea of

misunderstanding will be considered on account of the ignorance thereof. If the Bidder or Contractor shall discover any provision in the plans, specification, or contract which is contrary to or inconsistent with any such law, ordinance, rule or regulation, he shall forthwith report it to the Engineer in writing.

### **INTERPRETATIONS OF ADDENDUM**

If any person contemplating submitting a bid for this contract is in doubt as to the true meaning of any part of the plans, specifications, or other proposed contract documents, he may submit to the Director a written request for interpretation thereof. The person submitting the request will be responsible for the prompt delivery before one week prior to the date affixed for the opening of bids. Any interpretation of the proposed contract documents will be made only by Addendum duly issued, and a copy of such Addendum will be mailed directly to each person receiving a set of such documents. The City will not be responsible for any other explanation or interpretations of the proposed documents.

### **DELIVERY AND OPENING OF PROPOSALS**

Proposals shall be submitted in triplicate with all blanks filled in. They shall be enclosed in sealed envelopes, endorsed, and delivered as stated in the Advertisement. If forwarded by mail, the above-mentioned envelope shall be enclosed in another envelope addressed to the Manager, Division of Procurement and Records, City/County Building, Wilmington, Delaware, preferably by registered mail. No responsibility shall be attached to any persons for the premature opening of any proposal not properly endorsed.

Proposals will be publicly opened and read aloud at the time and place stated in the Advertisement. Bidders or their authorized agents are invited to be present.

### **WITHDRAWAL OF PROPOSALS**

Any bid may be withdrawn prior to the scheduled time for the opening of bids or authorized postponement thereof. No bid may be withdrawn within thirty (30) days after the actual opening thereof.

### **QUALIFICATIONS FOR BIDDERS**

No contract will be awarded to any bidder who, in the judgment of the Manager, is not a responsible bidder, or is not prepared with all the necessary experience, capital, organization and equipment to conduct and complete work for which the bidder proposes to contract, in strict accordance with all terms and provisions of the contract documents.

In each instance when the qualifications of any bidder are questioned in any way, such bidder shall furnish information concerning his experience, capital, organization and equipment as may be required by the Owner within five (5) days after written notice from the Board to do so, and the information so furnished by the bidder, together with any other information received or possessed by the Owner, will be taken into consideration by the Manager in awarding the contract.

### **RIGHT TO REJECT BIDS**

The Manager expressly reserves the right to reject any or all bids, or to accept any bid, and/or to waive technicalities as he may deem to be in the best interest of the City. The successful bidder will be required to have or obtain an appropriate Business License from the Department of Finance, Earned Income Tax Division, of the City of Wilmington in order to be awarded the contract.

### **MATERIAL SAMPLES**

Before any contract is awarded, the Bidder may be required to furnish a complete statement of the origin, composition and manufacture of any and all materials to be used in the work, together with samples, which samples may be subjected to the tests provided for in these specifications to determine their quality and fitness for the work.

### **AWARD AS AN ENTIRETY**

While bids are asked for by items, the contract will not be awarded by items, but will be awarded as an entirety, on the basis of the "Bid Total," which total must be the aggregate sum of the bids on all items figured at the unit and lump sum prices bid. Bidders shall bid on all items.

### **EXECUTION OF CONTRACT**

The successful bidder will be required promptly to execute a formal contract upon blank forms with proper insertions furnished by the Owner. Successful bidder will insert on the first page of the contract the date of the day the contract is executed by his company. All copies of the Contract must be properly executed by qualified officers of the company and the Corporate Seal affixed thereto.

### **FAILURE TO EXECUTE CONTRACT**

Failure to execute the contract within ten (10) days after written notice of the award, shall be just cause for the annulment of the award, and it is understood by the Bidder, in the event of the annulment of the award, that the amount of the certified check with the proposal may be forfeited to the use of the City, not as a penalty, but as liquidated damages.

### **COMMENCEMENT OF WORK**

Work at the site shall be commenced within ten (10) days after the date of the contract and shall be completed within the time stated in the proposal.

## AVAILABILITY OF FUNDING

The Contract shall be subject to the availability of funding approved by the Wilmington City Council. Contractor shall not exceed the total value of the City of Wilmington's purchase order for this Contract.

## AWARD AND EXECUTION OF CONTRACT

1. **Consideration of Proposals.** After the proposals are opened and read, they will be compared on the basis of the summation of the products of the approximate quantities shown in the bid schedule by the unit bid prices, unless the proposals states a different basis for comparing bids. In the event of a discrepancy between unit bid prices and extensions, the unit bid price shall govern.

Before awarding the contract, a bidder may be required to show that he/she has the ability, experience, necessary equipment, experienced personnel, and financial resources to successfully carry out the work required by the contract.

The right is reserved to reject any and/or all proposals, to waive technicalities, to advertise for new proposals, or to proceed to do the work otherwise, if in the judgment of the department, the best interest of the City will be promoted thereby.

2. **Award of Contract.** The award of contract, if it be awarded, must be within thirty (30) calendar days after the opening of proposals to the lowest responsible and qualified bidder whose proposal complies with all the requirements prescribed. The successful bidder will be notified by letter mailed to the address shown on his proposal that his bid has been accepted and has been awarded the contract.
3. **Cancellation of Award.** The City reserves the right to cancel the award of any contract at any time before the execution of said contract by all parties without any liability against the City.



# **Construction Contracts**

## **General Conditions**

### **COMPENSATION AND LIABILITY INSURANCE**

Except as otherwise provided by law, the Contractor shall, at all times, maintain and keep in force such insurance as will protect him from claims under workmen's compensation acts, also such insurance will protect him and the City from any other claims for damages for personal injuries, including death, which may arise from operations under this contract, whether such operations be by the Contractor or by any subcontractor or anyone directly or indirectly employed by any of them, in any amount specified by the Chief Engineer of the Department of Public Works. The Contractor shall also, at all times, maintain and keep in force such insurance, in an amount specified by the Chief Engineer of the Department of Public Works, as will protect him and the City, its agents and employees from all suits, actions, claims, demands, damages, losses, expenses, and/or costs of every kind and description to which the City may be subjected or put by reason of injury (including death) to persons or property resulting from the manner or method employed by the Contractor, his agents and employees, or subcontractors, or from any neglect or default of the Contractor, his agents, employees, or subcontractors, in the performance of this contract, or any part thereof, or from, by, or on account of any act or omission of the Contractor, his agents and employees, or subcontractors, and whether such suits, claims, actions, demands, damages, losses, expenses, and/or costs be against, suffered, or sustained by other corporations and persons to whom the City, its agents and employees, may become liable therefor.

### **LIABILITY OF CONTRACTOR**

Whenever the Contractor is required by the existing State, Federal, local or municipal law, ordinance, rules or regulations, or by any State, Federal, local, or municipal laws, ordinances, rules or regulations that may be enacted hereafter pertaining to the work to be done under this contract, to secure any permits or licenses to carry on any operation or operations in connection with the performance of the contract and/or to act under the direction or supervision of a City official and/or employee in connection with any such operation or operations, the Contractor shall be solely liable for all suits, actions, costs and damages of every kind and description resulting or which may result, directly or indirectly, from any such operation or operations and shall indemnify and save harmless the City from any and all suits, actions, costs, and damages of every kind and description arising or which may arise, directly or indirectly from the said operation or operations.

### **INDEMNIFICATION OF THE CITY**

The contractor shall pay, indemnify, and save harmless the City, its agents and employees from all suits, actions, claims, demands, damages, losses, expenses, and/or costs of every kind and description to which the City may be subjected or put by reason of injury (including death) to persons or property resulting from the manner or method employed by the Contractor, his agents and employees, or subcontractors, or from neglect or default of the Contractor, his agents and employees or subcontractors in the performance of this contract or any part thereof or from, by, or on account of any act or omission of the Contractor, his agents and employees, or subcontractors, and whether such suits, actions, claims, demands, losses, expenses, and/or costs against, suffered, or sustained by the City, his agents and employees, may become liable therefor, and the whole, or so much of the monies due, or become due the Contractor under this contract or any other contract as may be considered necessary by the Engineer may be retained by the City until such suits or claims for damages shall have been settled or otherwise disposed of the satisfactory evidence to that effect furnished to the Engineer.

## **PATENTS**

Whenever any article, material, mean, appliance, process, composition, combination, or thing called for by these specifications is covered by Letters Patent, the successful bidder must secure, before using or employing such article, material, mean, appliance, process, composition, combination, or thing, the assent, in writing, of the Owner or Licensee of such Letter Patent and file the same with the Engineer.

The said assent is to cover not only the use, employment, and incorporation of said articles, materials, means, appliances, processes, compositions, combinations, or things in construction and completion of the work, but also the permanent use of said articles, materials, means, appliances, processes, compositions, combinations, or things, thereafter, by or on behalf of the City in the operation and maintenance of the project for the purpose for which it is intended or adapted.

The Contractor shall be responsible for any claims made against the City or any of its agents and employees for any actual or alleged infringement of patents by the use of patented articles, materials, means, appliances, processes, compositions, combinations, or things, in the construction, completion, and the use of the work, and shall save harmless and indemnify the City and its agents and the employees' fees which the City may be obliged to pay by reason of any actual or alleged infringement of Patents used in the construction, completion, maintenance, operation of the work and projects herein specified.

## **SCOPE OF WORK**

The work to be done under these specifications is to cover the completed work shown on the plans or called for in the specifications and other contract documents. The Contractor shall furnish all implements, machinery, tools, equipment, materials, and labor necessary to the performance of the work and shall furnish and do everything necessary to make the work perfect, complete, neat, and finished, and the Contractor shall leave all the work to be done under this contract in this condition at the time the work is finally inspected.

## **PERMITS, LICENSES, CHARGES, AND NOTICES**

The Contractor shall procure all permits and licenses, pay all royalties, charges, and fees, and give all notices necessary and incident to the due and lawful prosecution of the work.

## **ENGINEER MAY INCREASE OR DECREASE QUANTITIES**

The Engineer reserves the right to increase or diminish the amount of quantity of any unit price item included in the Bid or Proposal, wherever he deems it advisable or necessary so to do, and such increase or diminution shall in no way vitiate the contract.

The Contractor shall be paid for the actual amount of quantity of authorized work done or materials furnished under the unit price item of the "Bid or Proposal" at the price bid stipulated for such item. In case the amount of quantity of any item is increased as above provided, the Contractor shall not be entitled to any damages, or increased compensation over and above the price bid for such item, and in case the amount of quantity of any item is diminished as above, provided, the Contractor shall not have any claim for damages on account of loss of anticipated profits or otherwise, because of such diminution.

## **EXTRA WORK**

The Contractor shall perform extra work, for which there is no quantity and price, included in the contract, whenever, to complete fully the work contemplated, it is deemed necessary or desirable, by written authority of the Engineer, and such extra work shall be done in accordance with the

specifications therefore, or in the best workmanlike manner as directed. This extra work will be paid for at a unit price or lump sum to be agreed upon previously, in writing, by the Contractor and the Engineer, or where such a price or sum cannot be agreed upon by both parties, or where this method of payment is impracticable, the Engineer may order the Contractor to do such work on a "force account" basis.

### FORCE ACCOUNT WORK

All extra work done on a "force account" basis will be paid for in the following manner:

1. For all labor and foremen in direct charge of the specific operation, the Contractor shall receive the rates of wage applicable to this contract, for each and every hour that said labor and foreman are actually engaged in such work.
2. For all material used, the Contractor shall receive the actual cost of such materials, as shown by original receipted bills.
3. An additional amount of twenty-five percent (25%) of the total cost of labor and materials of 1 and 2 above shall be added to allow for profit and overhead of subcontractors and a Contractor.
4. For any machine-power tools or equipment and for any hauling equipment, including fuel and lubricants, which it may be deemed necessary or desirable to use, the Engineer shall allow the Contractor a reasonable rental price, to be agreed upon in writing before such work is begun, for each and every hour that said tools or equipment are in use or on such work, and to its sum no percentage shall be added.

The compensation as herein provided shall be received by the Contractor as payment in full for extra work done on a "force account" basis, and shall include superintendents, use of tools and equipment to which no rental is allowed, and profit. The Contractor's representative and the Inspector shall compare records of extra work on a "force account" basis at the end of each day. Copies of these records shall be made in duplicate, upon the Engineer's "force account" forms provided for this purpose by the Inspector and signed by both the Inspector and the Contractor's representative, one copy being forwarded respectively to the Engineer and to the Contractor. All claims for extra work done on a "force account" basis shall be submitted to the Engineer by the Contractor upon certified triplicate statements, which shall also include the value of all material used in such work, and following that in which the work was actually performed and shall include all labor charges, etc., and material charges insofar as they can be verified.

Should the Contractor refuse or fail to prosecute the work as directed or submit his claim as required, the Engineer may withhold payment of all current estimates until the Contractor's refusal or failure is eliminated, or after giving the Contractor due notice, the Engineer may make payment for said work on the basis of reasonable estimate of the value of the work performed.

On extra work as defined in this paragraph, the Contractor will be reimbursed for his expenditures for Workmen's Compensation Insurance, Social Security taxes, and Unemployment Compensation covering the men actually engaged upon such work. No percentage will be added to such payments, but the Contractor shall be entitled to receive only the actual amount of money expended for such Workmen's Compensation Insurance, Public Liability Insurance, Social Security taxes, and Unemployment Compensation. Such payments shall be based upon the prevailing standard insurance

rates support by receipted vouchers from the insurance vendors and upon the actual amount of taxes paid for Social Security and Unemployment Compensation as evidenced by proper documents furnished by the Contractor.

### **EXTENSION OF TIME**

Should the Contractor allege to be delayed in the completion of the work by the act, neglect, or default of the Owner, Engineer or any other contractor employed by the Owner under the work, or by damage, caused by fire, flood, or other casualty for which the Contractor is not responsible, he may petition that the time fixed for completion of the work will be extended for a period equivalent to the time lost by any or all that causes aforesaid, which extended period shall be determined and fixed by the Engineer, but no such allowance will be made unless a claim therefore is presented in writing to the Engineer within five (5) days of the occurrence of such delay, and then only when granted in writing with the signature of the Engineer.

### **UNAUTHORIZED WORK**

Work done beyond the lines and grades shown on the plans or as given, except as herein provided, or any extra work done without written authority, will be considered as unauthorized and at the expense of the Contractor and will not be measured by the Engineer or paid for by the City. Work so done may be ordered removed and replaced by the Engineer at the Contractor's expense.

### **PROSECUTION OF WORK**

The Contractor shall begin work to be performed under the contract within ten (10) days after the date of the contract. The place where the work is to be started will be designated on the ground by the Engineer. The work shall be prosecuted from as many different points, in such part or parts and at such time as may be directed, and shall be conducted in such a manner and with sufficient materials, equipment, and labor as is considered necessary to insure its completion within the time set forth in the contract.

Should the prosecution of the work for any reason be discontinued by the Contractor with the consent of the Engineer, he shall notify the Engineer at least twenty-four (24) hours before again resuming operations.

### **EMPLOYEES AND EQUIPMENT**

Any employees of, or person connected with the Contractor, who shall use profane or abusive language to the Inspector, or other employees of the City, or otherwise interfere with him in the performance of his duties, or shall disobey or evade his instructions, or who is careless or incompetent, or is objectionable to the City authorities, shall be discharged on the request of the Engineer, and shall not again be employed without his consent.

The Contractor shall furnish such equipment as is considered necessary by the Engineer for the prosecution of the work in an acceptable manner and at a satisfactory rate of progress. Equipment used on any portion of the work shall be such that no injury to adjacent work or property will result from its use.

## COOPERATION OF CONTRACTOR AND REPRESENTATIVE

The Contractor shall give the work his constant attention to facilitate the progress thereof and shall cooperate with the Engineer in every way possible. The Contractor shall have at all times competent and reliable English-speaking representatives on work, authorized to receive orders and act for him.

## LAWS TO BE OBSERVED

The Contractor at all times shall observe and comply with all Federal, State, local and municipal laws, ordinances, rules, and regulations in any manner effecting the work, and all such orders or decrees as exist at present and those which may be enacted later, of bodies or tribunals having any jurisdiction or authority over the work, and shall indemnify and save harmless the City and all its officers, agents, and servants against any claim or liability arising from or based on the violation of any such law, ordinance, regulation, rule, order, or decree, whether such violations be by the Contractor, or any subcontractor, or any of their agents, and/or employees.

## SANITARY PROVISIONS

The Contractor shall provide and maintain a neat sanitary condition, such sanitary conveniences and accommodations for the use of his employees as may be necessary to comply with the requirements and regulations of the Department of Health or of other bodies or tribunals having jurisdiction thereof. He shall commit no public nuisance.

## WATER SUPPLY

Where water directly from the City-owned water mains is available, it will be supplied to the Contractor upon request and approval, at regular meter and/or rental rates, at the nearest available hydrant or outlet, and no other water shall be used for any purposes connected with the contract, except by permission of the Engineer.

The Contractor will be required to provide approved, standard tight hose, and fittings with which to make connection to hydrants and outlets. No improper, wasteful, or undue use of water will be permitted.

The Contractor shall procure from the Water Department a regular wrench for use on hydrants and no other wrench shall be used. He shall conform to all the rules and regulations of the Water Department in connection with the use of water hydrants, pipes, etc.

Where water directly from the City-owned water mains is not available, the Contractor shall, at his own cost and expense, provide such quantities of clean water as may be required for any and all purposes under the contract. He shall supply sufficient drinking water to allow his employees, but only from such sources as are approved by the Engineer and no other water shall be used for drinking purposes.

## PUBLIC CONVENIENCE AND SAFETY

The Contractor at all times shall conduct the work in such a manner as to insure the least obstruction to traffic practicable. The convenience of the general public and of the residents and occupants or property along and adjacent to the work shall be provided for in an adequate and satisfactory manner. Materials stored upon highway shall be placed so as to cause as little obstruction to the traveling public as is considered necessary. Fire hydrants on or adjacent to the work shall be kept accessible to fire apparatus at all times, and no material or obstruction shall be placed within fifteen (15) feet of any such hydrant. Footways and portions of highways and streams adjoining the work under construction shall not be obstructed more than is absolutely necessary. All gutters and sewer inlets shall be kept

unobstructed at all times. In no case, shall any traveled thoroughfare be closed without permission of the Engineer.

### **MAINTENANCE OF TRAFFIC**

The Contractor shall submit a maintenance of traffic plan for approval by the Engineer seven (7) days prior to start of work. The maintenance of traffic plan shall contain only approved traffic control devices and methods of operation in accordance with the State of Delaware "Manual on Traffic Control for Street/Highway Construction and Maintenance Operations." The Contractor shall not perform any work until the maintenance of traffic plan has been approved in writing by the Engineer.

The Contractor shall not enter upon private property for any purpose without obtaining permission, and shall be responsible for the preservation of all public and private property, trees, monuments, etc., along and adjacent to the work and shall use every precaution necessary to prevent damage or injury to property or persons. He shall use suitable precautions to prevent damage to pipes, conduits, and other underground structures and shall protect carefully from disturbances or damage of all and monuments and property marks until an authorized agent has witnessed or otherwise referenced their location, and shall not remove them until directed. The Contractor shall not willfully nor maliciously injure or destroy trees or shrubs and shall not remove or cut them without proper authority. He shall be strictly responsible for any and all damage or injury of every kind and description, which directly or indirectly may be done to any property or sustained by any persons during the prosecution of the work resulting from any wrongdoing, misconduct, want of skill, or any negligence of himself or his agents and/or employees, or at any time due to defective work or materials. Where or when any direct or indirect damage or injury is done to public or private property by or on account of any act, omission, neglect, or misconduct in the execution of the work or in consequence of the non-execution thereof on part of the Contractor, he shall restore, at his own expense, such property to a condition similar or equal to that existing before such damage or injury was done by repairing, rebuilding, or otherwise restoring as may be directed, or he shall make good such damage or injury in an acceptable manner. In case of the failure on the part of the Contractor to restore such property, or make good such damage or injury, the Engineer may, upon three (3) days notice, proceed to repair, rebuild, or otherwise restore such property as may be deemed necessary, and the cost thereof may be deducted from any monies due or which may become due to the Contractor under this contract.

### **DAMAGE TO UTILITIES**

Should the Contractor or his workmen in the execution of this contract cause damage to any underground construction, such as water, telephone, electric, and police conduit, such damage shall be repaired or replaced by the Contractor at his own expense and under the direction of the Engineer; or such repairs to the damaged utility or utilities may be made by employees of the respective utility company or companies whose underground structure was damaged by the Contractor or his workmen and such costs for these repairs shall be paid by the Contractor.

### **CONTRACTOR'S RESPONSIBILITY FOR WORK**

Until the final acceptance of all work, as indicated in writing by the Engineer, it shall be under the charge of and care of the Contractor and he shall take every precaution against the destruction, injury or damage to the work or to any part thereof by the action of the elements or from any other cause whatsoever. The Contractor shall rebuild, repair, restore, and make good, at his own expense, all destruction of, injuries or damages to the work, or any portion thereof, occasioned by any of the above causes before its final completion and acceptance as indicated in writing by the Engineer.

### **SUPERVISION BY ENGINEER**

The work is to be carried out under the supervision of the Engineer to his entire satisfaction. The work and materials shall be strictly of the best quality of the kinds specified herein, and should any work or materials other than those specified as shown be introduced into the construction of the work, the Engineer, or his authorized agent, shall have full power to reject them, and they shall be removed from the premises in three (3) days by the Contractor after being notified to do so.

### **AUTHORITY OF ENGINEER**

The Engineer shall in all cases determine the amount of quantity, quality, acceptability of the work and materials which are to be paid for under this contract and shall decide all questions in relation to said work and the performance thereof; and shall, in all cases, decide questions which may arise relative to the fulfillment of the contract to the obligations of the Contractor thereunder.

### **AUTHORITY AND DUTIES OF INSPECTORS**

Inspectors employed by the Owner shall be authorized to inspect all work done and materials furnished. Such inspection may extend to all or part of the work to the preparation or manufacture of the materials to be used. An inspector will be stationed on the work to report to the Engineer as to the progress of the work and the manner in which it is being performed; also to report whenever it appears that the materials furnished and the work performed by the Contractor fail to fulfill the requirements of the specifications and contract, and to call to the attention of the Contractor any such failure or other default, but no inspection, nor any failure to inspect, at any time or place, however, shall relieve the Contractor from any obligation to perform all of the work strictly in accordance with the requirements of the specifications. In case of any dispute arising between the Contractor and the Inspector as to materials furnished or the manner of performing the work, the Inspector shall perform such other duties as are assigned to him. He shall not be authorized to revoke, alter, enlarge, relax, or release any requirements of these specifications, not to approve or accept any portion of the work, nor interfere with the management of the work by the Contractor. Any instructions which the Inspector may give the Contractor shall in no way be construed as binding by the Engineer or the City in any way, nor releasing the Contractor from the fulfillment of the terms of the contract.

### **INSPECTION OF MATERIALS AND WORK**

The Contractor shall furnish the Engineer with every reasonable facility for ascertaining whether or not the work as performed is in accordance with the requirements and intent of the specifications and contract. If the Engineer requests it, the Contractor, at any time before acceptance of the work, shall remove and/or uncover such portions of the finished work as may be directed. After examination, the Contractor shall restore said portions of the work to the standards required by the specifications. Should the work thus exposed or examined prove acceptable, the uncovering, removing, replacing the covering, and/or making good the parts removed shall be paid for as "Extra Work," but should the work exposed or examined prove unacceptable, either in whole or in part, the uncovering, removing, replacing of the covering and/or making good of the parts removed, shall be at the Contractor's expense.

### **DEFECTIVE MATERIALS AND WORK**

All materials not conforming to the requirements of these specifications shall be considered defective, and all such materials, whether in place or not, shall be rejected and shall be removed immediately from the work unless otherwise permitted. No material which has been rejected, the defects of which have been corrected or removed, shall be used until approval has been given. All work which has been rejected or condemned shall be remedied, or if necessary, removed and replaced in an acceptable manner by the Contractor at his own expense.

### **FAILURE TO REMOVE AND RENEW DEFECTIVE MATERIALS AND WORK**

Should the Contractor fail or refuse to remove and renew any defective materials used or work performed previously, or to make any necessary repairs in an acceptable manner, and in accordance with the requirements of these specifications, within the time indicated in writing, the Engineer shall have the authority to cause the unacceptable or defective materials or work to be removed and renewed for such repair to be made at the Contractor's expense. Any expense incurred by the City in making these removals, renewals, or repairs, which the Contractor has failed or refused to make, shall be paid out of the monies due or which are to become due to the Contractor; and continued failure or refusal on the part of the Contractor to make any or all necessary repairs, removals and renewals, promptly, fully, and in an acceptable manner shall be sufficient cause for the City to declare the contract forfeited, in which case, the City at its option may be required to perform the work, or may contract with any other individual, firm, or corporation to perform the work. All costs and expenses incurred thereby shall be charged against the defaulting contractor, and the amount thereof deducted from any monies due or to become due him. The performance of any work by the City and/or others as specified shall not relieve the contractor in any way from his responsibilities under this contract.

### **CLEANING UP**

The Contractor shall at his own expense, keep the sites of his operations clean during the construction and remove all rubbish as it accumulates.

Upon failure of the Contractor to keep sites of his operation clean to the satisfaction of the Engineer, the City may upon twenty-four (24) hours notice to the Contractor, remove any rubbish, materials, earth, etc., which the Engineer may deem necessary, charging the cost thereof to the Contractor and may deduct the amount from any monies that may be due him. On or before the completion of the work, the Contractor shall, without charge therefore, tear down and remove all his buildings and temporary structures built by him, shall remove all rubbish of all kinds from any grounds which he has occupied, and shall leave the site of the work in a clean and neat condition.

### **TEMPORARY SUSPENSION OF WORK**

The Engineer shall have the authority to suspend the work, wholly or in part, for such a period or periods as he may deem necessary, due to unsuitable weather, or such other conditions as are considered unfavorable for the suitable prosecution of the work, or for such time as is necessarily due to the failure on the part of the Contractor to carry out orders given or perform any or all provisions of the contract. If it should become necessary to stop work for an indefinite period, the Contractor shall store all materials in such a manner that they will not obstruct or impede the traveling public unnecessarily, nor become damaged in any way, and he shall take every precaution to prevent destruction, damage, or deterioration of the work performed to provide suitable roof drainage, and erect temporary cover where necessary. The Contractor shall not suspend the work without authority. Neither the failure of the Engineer to notify the Contractor to suspend work on account of bad weather, or other unfavorable conditions, nor permission by the Engineer to continue work during bad weather or other unfavorable conditions, shall be a cause for the acceptance of any work which does not comply in every respect with the contract and specifications.

### **ANNULMENT OF CONTRACT**

If the Contractor fails to begin the work under the contract within the time specified, or fails to perform the work with sufficient materials to insure proper completion of said work, except in cases for which an extension of time is provided, or shall perform the work unsuitably or neglect or refuse to promptly remove materials or again promptly perform such work as shall be rejected as defective or of unsuitable or shall discontinue the prosecution of the work, or if the Contractor becomes insolvent or to be declared bankrupt, or commit any act of bankruptcy or insolvency, or allow any final judgment to stand



against him unsatisfied for a period of forty-eight (48) hours or shall make an assignment for the benefit of creditors or shall fail to make prompt payment for all subcontractors and/or material, for material and/or labor supplied, or shall persistently disregard any State, Federal, local or municipal laws, ordinances, rules, or regulations pertaining to the work or shall disregard the instructions of the Engineer, or from any other cause whatsoever shall not carry on the work in an acceptable manner, the Engineer may give notice in writing, mailed to the Contractor and/or Surety of such delay, neglect, default, specifying same, and if the Contractor within the period of three (3) days after such written notice is mailed, shall not proceed in accordance with same, then the City shall upon written certificate from the Engineer of the fact such delay, neglect, or default, and the Contractor's failure to comply with such notice, have full power and authority without prejudice to any of its other rights or remedies and without violating the contract, to terminate the employment of said Contractor and to take prosecution of the work out of the hands of said Contractor and to take possession of the premises and to appropriate the use of any or all materials, appliances, and equipment on the premises, and may enter into an agreement for the completion of said contract according to the terms and provisions thereof, or use such other methods as in its opinion, shall be deemed expedient and necessary for the completion of said contract in accordance with the plans and specifications, and within such time as in the judgment of the City, the public interests may require. In the event of any of the aforementioned circumstances arising at any time or times, the City shall have the right to withhold, without the payment of interest, any sum or sums of money due or to become due the Contractor until the interests of the City have been fully protected to the satisfaction of the Engineer. All costs and expenses incurred by the City together with the cost of completing the work under the contract, including the cost of additional managerial and administrative services, if any, shall be deducted from the monies due or which may become due said Contractor. In the case of expense so incurred by the City shall be less than the sum which would have been payable under the contract if it had been completed by said Contractor, then the said Contractor shall be entitled to receive the difference; and in case such expense shall exceed the sum which would have been payable under the contract, Contractor and/or Surety shall be liable therefor, and shall pay the amount of the differences to the City within ten (10) days after written notices mailed to the Contractor and/or Surety. The expense, loss, or damage, including the cost of additional managerial and administrative services, if any, incurred by the City through the Contractor's default shall be certified by the Engineer, and such certification shall be conclusive and recognized and accepted as the correct amount of the loss sustained by the City and all parties concerned.

### **MEASUREMENT OF QUANTITIES**

All work completed under the contract shall be measured by the Engineer according to the United States Standards of Measures.

### **MATERIALS AND WORK NOT PAID FOR BY THE CONTRACTOR**

When written notice is given to the Engineer before or within ten (10) days after the completion and conditional acceptance of the entire work under the contract by persons having done work or furnished materials for such contract that there is money due and unpaid for said work and materials, the Contractor shall furnish the Engineer with satisfactory evidence that said money has been fully paid for satisfactorily secured by him. In case such evidence is not furnished as aforesaid, such amounts as may be necessary to meet the claims of the persons or aforesaid may be retained from any monies due the Contractor under the contract until the liabilities aforesaid shall be fully discharged or such notices withdrawn. The City or the Engineer may also, with the written consent of the Contractor, use any money retained, due or become due under the contract, for the purpose of paying for both labor and materials for the work, for which claims have been filed in the office of the Engineer.

## NO ESTOPPEL OR WAIVER OF LEGAL RIGHTS

The City, or the Engineer, shall not be precluded or estopped by any measurement, estimate, or certificate made or given by them, or by any agent or employee of the City, under any provision or provisions of the contract, at any time, either before or after the completion and acceptance of the work and payment therefor, pursuant to any measurement, estimate or certificate from showing the true and correct amount and character of the work performed and materials furnished by the Contractor or from showing at any time that any such measurement, estimate, or certificate is untrue or incorrectly made in any particular, or that the work or materials or any part thereof, do not conform in fact to specifications and contract, and the Engineer shall have the right to reject the whole or any part of the aforesaid work or materials, should the said measurement, estimate, or certificate or payment be found or be known to be inconsistent with the terms of the contract, or otherwise improperly given, the City shall not be precluded and estopped, notwithstanding any such measurement, estimate, certificate, and payment in accordance therewith from demanding and recovering from the Contractor and his Surety such damages as it may sustain by reason of his failure to comply with terms of the specifications and contract. Either the acceptance by the City, the Engineer, or any agent or employee of the City, nor any certificate by the City for payment of money, nor any payment for, nor acceptance or use of, the whole or any part of the work, by the City or the Engineer, nor any extension of time, nor any possession taken by the City or its employees, shall operate as a waiver of any portion of the contract, or of any power herein reserved by the City, or any right to damages herein provided, nor shall any waiver of any breach of the contract be held to be a waiver of any other or subsequent breach.

## SUBCONTRACTORS

The Contractor shall give his personal attention to the faithful performance of the work, shall keep the same under his control, and shall not assign the contract by power of attorney or otherwise, nor sublet the work or any part thereof, without the previous written consent of the Engineer; he shall state to the Engineer in writing the name of each subcontractor he intends employing, the portion of work which he is to do or the materials which he is to furnish, his place of business and such other information as the Engineer may require, in order to know whether or not said subcontractors are reputable and reliable and able to perform the work or to furnish the materials as called for in the specifications. No subcontractor shall be engaged upon any branch of the work who is not thoroughly practical and responsible and at the time of making this contract, conducting business in the particular branch or trade for which he is employed.

The Contractor shall not, either legally or equitably, assign any of the monies payable under the contract, or his claims thereto, unless by and with the consent of the Engineer.

The Contractor shall not be released from any of his liabilities or obligations under this contract should any subcontractor or subcontractors fail to perform in the satisfactory manner the work undertaken by him or them.

The Contractor agrees that he is fully responsible to the City for the acts or omissions of his subcontractor, and of persons either directly or indirectly employed by them, as he is for the acts or omissions of persons directly or indirectly employed by him.

Subcontracts, if any, shall be let promptly after the signing of the contract.

Nothing contained in the contract shall create any contractual relation between any subcontractor and the City.

The Contractor shall furnish the City with a written list of all subcontractors, if any, to be used in connection with this contract. The City reserves the right to reject the use of any subcontractors for any reason whatsoever.

### **CLAIMS TO BE MADE PROMPTLY**

Should the Contractor be of the opinion, at any time or at times, that he is entitled to any additional compensation whatsoever (over and above the compensation stipulated in these contract documents or for quantities and/or amounts over and above the quantities and/or amounts allowed or approved by the Engineer), the damages, losses, costs, and/or expenses alleged to have been sustained, suffered, or incurred by him in connection with the project herein contemplated, he shall, in each instance, within five (5) days after such alleged damages, losses, costs, and/or expenses shall have been sustained, suffered, or incurred, make a written claim therefor to the Engineer. On or before the fifteenth (15th) day of the calendar month succeeding that in which such damages, losses, costs, and/or expenses shall have been sustained, suffered, or incurred, the Contractor shall file with the Engineer a written, itemized statement of the detailed amounts of each such claim or damage, loss, cost, and/or expense and unless such claim for such additional compensation shall be held and taken to be absolutely invalidated, and he shall not be entitled to any compensation on the account of each such alleged damage, loss, cost, and/or expense.

The provisions of this section shall be held and taken to constitute a condition precedent to the right of the Contractor to recover; they shall also apply to all claims by the Contractor in any way relating to the complete project; and even though the claims and/or work involved may be regarded as "outside the contract."

It is understood and agreed, however, that nothing in this section contained shall be held or taken to enlarge in any way the rights of the Contractor or the obligations of the City under these contract documents.

### **EXTRA WORK A PART OF THE CONTRACT**

No order for extra work nor the doing of any extra work, at any time or place, shall in any manner or to any extent relieve the Contractor from any of their obligations under the contract documents; all extra work orders being given and all extra work being done, under, and in accordance with the contract are to be considered a part of the same and subject to each and every one of the terms and requirements of the contract documents.

### **SCOPE OF PAYMENT**

The Contractor shall receive and accept the compensation, as provided in the Bid or Proposal, in full payment for furnishing all materials, labor, tools, and equipment and for performing all work contemplated and embraced under the contract. Also for all loss of damages arising out of the nature of the work, or from the action of the element or from any unforeseen difficulties or obstructions, which may arise or be encountered during the prosecution of the work, until its final acceptance by the City, and for risks of every description connected with the prosecution of the work, until its final acceptance by the City, and for all risks of every description connected with the prosecution of the work, also for all expenses incurred by, or in consequence of the suspension or discontinuance of the prosecution of the work as herein specified, and for any actual or alleged infringement of patent, trade name, or copyright and for completing the work and the whole thereof, in an acceptable manner according to the plans and specifications. The payment of any current or final estimate, or of any retained percentage, shall in no way or in a degree, prejudice, or affect the obligations of the Contractor, at his own cost and expense, to renew or replace any defects and imperfections in the construction of the work or in the strength of the quality of materials used in or about the construction of the work under contract and its appurtenances, as well as all damages due or attributable to such defects, which defects,

imperfections, or damages shall be discovered on or before the final inspection and acceptance of the work, and of which defects, imperfections, or damages, the Engineer shall be the judge, and the said Contractor shall be liable to the City for failure so to do.

### **PARTIAL PAYMENTS**

The Engineer will make current estimates in writing, once each month, of the materials in place complete, and the amount of work performed in accordance with the contract, during the preceding month or period, and the value thereof figured at the unit prices of the contract, and in case of lump sum items, figured on the basis of the schedule of values to be agreed upon, as therein after provided for.

For the total of the amounts so ascertained will be deducted an amount equivalent to ten percent (10%) of the whole to be retained by the City until after the completion of the entire contract, in an acceptable manner, and the balance or sum equivalent to ninety percent (90%) of the whole, shall be paid to the Contractor by the City.

Schedule of values of the various parts of work to be done under lump sum items shall be agreed upon by the Contractor and the Engineer, and such schedules shall be the basis for determining the amount allowed the Contractor on account of such lump sum items, partial estimates, or payment under the contract.

### **PAYMENTS MAY BE WITHHELD**

Payments may at any time be withheld if the work is not proceeding in accordance with the contract, or if, in the judgment of the Engineer, the Contractor is not complying with requirements of the contract documents.

### **CONDITIONAL ACCEPTANCE**

Whenever, in the opinion of the Engineer, the Contractor shall have completed the work in an acceptable manner in accordance with the terms of the contract, the Engineer shall make an inspection of the entire work, and upon inspection and acceptance, completion of all repairs and renewals which may appear at the time to be necessary, in the judgment of the Engineer, he shall certify to the owner in writing as to said completion, and as to the value thereof. The aforesaid certificate shall be held and taken to evidence the conditional acceptance of the entire work by the Owner as of the date thereof, and an additional five percent (5%) of the whole value of the work over and above any and all other reservations and/or deductions which the City is, by the terms of the contract documents or otherwise, entitled or required to make and obtain and shall hold said five percent (5%) for a period of three (3) months from and after the date of such certificate and conditional acceptance, and the City shall be authorized to apply the whole or any part of said five percent (5%) so retained to any and all costs of repairs and renewals of the work and appurtenances which may become necessary, in the judgment of the Engineer, during such period of three (3) months on account of any failure or defects in said work and appurtenances due to improper work done or materials furnished by the Contractor, if the Contractor shall fail to make such repairs or renewals within three (3) days after receiving notice from the City to do so.

### **FINAL ACCEPTANCE OF PAYMENT**

Upon the expiration of the aforesaid three (3) months from and after the date of certificate of conditional acceptance of the work, the Engineer shall make final inspection of the entire work, and upon confirmation of all repairs and renewals which may appear at that time to be necessary in the judgment of the Engineer, he shall certify to the Owner in writing as to the final acceptance of the entire project. The Owner, upon receipt and approval of said certificate, shall pay, or cause to be paid under the

contract, except such sums which have already been paid and except such sum or sums as may have been expended by the Owner under the provisions of the contract documents and less any other deductions the Owners may be otherwise entitled to make.

The last mentioned certificate issued by the Engineer shall be deemed and accepted by all of the parties hereto as evidencing the final completion and acceptance of the entire project, and the payment made by the Owner to the Contractor pursuant to the issuance of said certificate of final completion and acceptance shall be deemed to be accepted by all of the parties hereto as the final payment to be made by the Owner to the Contractor, all prior certificates or estimates upon which payments may have been made being partial estimates and subject to correction in said final payment.

#### **LAST PAYMENT TO TERMINATE LIABILITY OF THE OWNER**

The acceptance by the Contractor of the final payment shall operate as and be a release of the Owner and every agent thereof from all claims and liabilities to the Contractor for anything done or furnished or relating to the work, or for any act or neglect of the Owner or any persons relating to or affecting this work.

#### **NO LIMITATION OF LIABILITY**

It is understood and agreed that any and all duties, liabilities, and/or obligations imposed upon or assumed by the Contractor and the Surety, or either of them by or under the contract documents, shall be taken and construed to be cumulative, and that the mention of any specific duty, liability, or obligation imposed upon or assumed by the Contractor and/or Surety under the contract documents shall not be taken or construed as a limitation or restriction upon any or all of the other duties, liabilities and/or obligations imposed upon or assumed by the Contractor and/or Surety by or under the contract documents.

#### **REMEDIES CUMULATIVE**

All remedies provided in the contract documents shall be taken and construed to be cumulative; that is, in addition to any and all other remedies provided therein and to any remedies in law or equity which the City would have in any case.

#### **LEGAL ADDRESS**

The address given in the bid or proposal is hereby designated as the legal address of the Contractor. Such address may be changed at any time by notice in writing delivered to the Engineer. The delivering of such legal address or the depositing in any post office, in a postpaid, registered wrapper direct to the above-mentioned address of any notice, letter, other communication to the Contractor, shall be deemed to be a legal and sufficient service thereof upon the Contractor.

#### **CONTRACTOR'S EXPENSE**

All things required by the contract documents to be done, furnished, and/or installed shall be done, furnished and/or installed by the Contractor at his entire cost and expense, unless otherwise provided therein.

#### **NIGHT, WEEKEND, AND CITY HOLIDAY WORK**

No night work between the hours of 5:00 p.m. and 8:00 a.m., no work on Saturday, Sunday, and no work on any City Holiday shall be permitted except with written permission of the Engineer. If the Contractor decides to work on those above days, he shall reimburse the City for the salaries and wages of the City Construction Inspectors. Compensation shall include direct payroll cost and fringe benefits.

The Contractor shall notify the Engineer in writing at least two (2) days in advance of such days he desires to work.

### **STRIKES, ETC.**

The Contractor shall adjust all strikes, or other labor troubles, and no allowance will be made for such delays in the time limit herein named.

### **ACCESS TO WORK**

The Engineer may at any time enter upon the work and the premises used by the Contractor, and the Contractor shall provide proper and safe facilities by means of ladders or otherwise to secure convenient access to all parts of the work, and all other facilities necessary for inspection, as may be required by the Engineer.

### **GUARANTEE**

The Contractor hereby guarantees all work performed under this contract for a period of one (1) year from the date of the "Final Acceptance and Payment" thereof by the City as follows:

Against all faulty or imperfect materials and against all imperfect, careless, and/or unskilled workmanship.

That the work performed under this contract, including all mechanical and electrical equipment and appurtenances, and each and every part thereof, shall operate (with proper care and maintenance) in a satisfactory and efficient manner and in accordance with the requirements of these contract documents.

The Contractor agrees to replace with proper workmanship and materials, and to re-execute, correct, or repair, without cost to the City, any work which may be found to be improper or imperfect and/or which does not operate in a satisfactory manner or fails to perform as specified.

The guarantee obligations assumed by the Contractor under these contract documents shall not be held or taken to be in any way impaired because of the specifications, indication or approval by or on behalf of the City of any articles, materials, means, combinations, or things used or to be used in the construction, performance, and completion of the work or any part thereof.

No use or acceptance by the City of the work or any part thereof, nor any failure to use the same, nor any repairs, adjustments, replacements, or corrections made by the City due to the Contractor's failure to comply with any of his obligations under these contract documents, shall impair in any way with the guarantee obligations assumed by the Contractor under these contract documents.

### **HOURS OF LABOR**

Eight (8) hours shall constitute a day's work for all laborers, workmen, or mechanics directly employed by the Contractor and all subcontractors on the project, except in time of war or at other times of emergency when it may be necessary to work more than eight (8) hours in any one calendar day to protect or save human life or property, and the Contractor or any of his subcontractors shall not require or permit any laborer, workmen, or mechanics to work more than eight (8) hours in any one calendar day while engaged on the project, except at times hereinbefore specifically mentioned.

### **WAGES PAYABLE UNDER MUNICIPAL CONTRACTS, ETC.**

SECTION 2-1, Wilmington Code, Chapter 20, Article IV.

SECTION 20-44

Definitions.

For the purposes of this article, the following words and phrases shall have the meanings respectively ascribed to them by this section:

- "City Work"** All building or construction work or projects of any kind or nature, including repair, alteration, and remodeling done on behalf of the City under any contract awarded by the City for building or constructing any building or structure, or the repair, alteration, and remodeling thereof or any other project subject to the determination by the Procurement and Records Division Manager and the State Department of Labor and Industrial Relations in accordance with the provisions of Sections 101 to 129 of Title 19 of the Delaware Code, involving the hourly wages for the respective occupational classifications within a given craft, trade, or industry for the City area.
- "Contractor"** Any employer who has been awarded any contract for the City work as defined herein.
- "Contracts"** Contracts for the performance of City work entered into by the City with contractors and all contracts entered into between such contractors and subcontractors involving or regarding such work.
- "Employee"** A workman or mechanic of the employer.
- "Employer"** Any person who is a party to a contract or subcontract for the performance of any City work as defined herein.
- "Occupational Classifications"** The specific categories of jobs within a given craft, trade, or an industry for which a separate hourly wage rate for the City area as is determined by the Procurement and Records Division Manager and the State Department of Labor and Industrial Relations in accordance with the provisions of Section 101-129 of Title 19 of the Delaware Code.
- "Prevailing Wages"** An aggregate of:
- 1) The hourly wages for the respective occupational classifications within a given craft, trade, or industry for the City area determined by the Procurement and Records Division Manager and the State Department of Labor and Industry Relations in accordance with the provisions of Sections 101-129 of Title 19 of the Delaware Code; provided, however, that during the period of any substantial work stoppage involving rates of wages in a given craft, trade, or industry, such wages for such craft, trade, or industry shall be those as last so determined by the Procurement and Records Division Manager prior to such work stoppage, and

- 2) The additional benefits, for which a monetary equivalent may be determined, and which are given employees pursuant to a bona fide collective bargaining agreement for their respective craft, trade, or industry in the City area, or the monetary equivalent of such benefits.

#### SECTION 20-45

##### Required Contract Provision

The specifications for all City work contracts shall contain a reference that the minimum wages paid for each occupation classification of employees shall be the prevailing wages as determined by the Procurement and Records Division Manager and the State Department of Labor and Industrial Relations. Each contract, as defined in this article, involving any City work shall contain a provision that all employees performing City work shall be paid at least the applicable prevailing wages. Every contract involving any City work shall contain a provision that the Contractor shall require all subcontractors to comply with and be bound by all of the provisions of this article.

As a condition precedent to awarding of any construction contract by the City, all bidders shall be compelled to agree and abide by any Federal, State, County, or municipal statutes, ordinances, or regulations thereof, pertaining to plans for the hiring of persons belonging to minority groups or to any reasonable plans or agreements formulated among the contractors, construction trade unions, and the various neighborhood civic groups concerned with the elimination of discriminatory hiring practices in the construction industry.

The awarding of any City construction contracts shall be made to the lowest responsible bidder who agrees to abide by all Federal, State, County or municipal statutes or ordinances, or rules or regulations which may prohibit the discriminatory hiring practices by a person's race, color, religion, national origin, or political opinion, and who further agrees to promptly comply with any reasonable plan to be formulated by the hiring of persons of minority groups that results from either Federal, State, County or City statutes, ordinances, rules and regulations, or agreements among the construction trade unions, the contractors, and the various neighborhood groups concerned with the elimination of discriminatory hiring practices.

The Finance Department's Division of Procurement and Records shall notify in writing, or include in all specifications, the pertinent provisions of this section, to apprise all bidders on City construction contracts of this requirement (Ordinance No. 70-055, Section 3).

#### SECTION 20-46

##### Affidavit of Compliance with Article Prerequisite to Payment by City; Monthly Payroll Report.

All contractors and subcontractors performing City work shall file with the Procurement and Records Division Manager, an affidavit upon each payment being made by the City to such contractors and subcontractors pursuant to a contract that the provisions of this article have been complied with prior to the City making any payment. The affidavit shall also provide that the contractor or subcontractor has posted in a conspicuous place on the job site a list of the prevailing wages for the respective occupational classifications; and he shall submit with the affidavit a monthly report stating the number of workers in each classification, and the total gross payroll paid by him to each classification (Ordinance No. 73-077, Section 1).



## SECTION 20-47

### Violation of Article.

The violation of this article shall be considered a substantial breach of contractor's obligation under the contract; provided, however, that this article shall not be deemed to have been violated where it is contended that a particular craft, trade or industry is not the appropriate one and the wages applicable to the craft, trade or industry working under the contract have been paid the prevailing wages as determined for the craft, trade or industry contract. No contract for City work shall be awarded to any contractor or subcontractor who has violated any provision of this section until five (5) years have elapsed from the date of determination of such violation, and shall be fined no more than five thousand dollars (\$5,000.00) for each violation (Ordinance No. 73-077, Section 2).

### PLANS, ETC., TO BE FOLLOWED

The approved plans attached to and made a part thereof will show the details and dimensions of the work contemplated, which shall be performed in strict accordance therewith and in accordance with the specifications. There shall be no deviation from the plans, specifications, etc., on account of the exigencies of construction, unless approved by the Engineer and authorized in writing.

### INTERPRETATION OF PLANS, ETC.

On all plans, drawings, etc., the following dimensions shall govern in the case of discrepancy between the scales and figures. The Contractor shall take no advantage of any error or omission in the plans or of any discrepancy between the plans and specifications, and the Engineer shall make such corrections and interpretations as may be deemed necessary for the fulfillment of the intent of the specifications and of the plans as construed by him. In all cases of doubt as to the true meaning of the specifications, plans and/or drawings, the decision of the Engineer will be final and conclusive.

### ALTERATION OF PLANS OR OF CHARACTER OF WORK

The Engineer reserves the right to make such alterations in the plans or in the character of the work as may be considered necessary or desirable from time to time to complete fully and perfectly the construction of the work, provided such alterations do not change materially the original plans and specifications of such alterations shall not be considered as a waiver of any condition of the contract nor to invalidate any of the provisions thereof. Should such alterations in the plans or in character of the work be productive of increased cost or result in decreased cost to the Contractor, a fair and equitable sum therefor to be agreed upon in writing by the Contractor and the Engineer, before such work is begun, shall be added to or deducted from the contract price, as the case may be. No allowance will be made for anticipated profits on the work omitted.

### PLANS AND SPECIFICATIONS FURNISHED TO CONTRACTOR

The Contractor will be supplied by the Engineer with a reasonable number of copies of the plans and specifications and he shall have available on the work at all times during the prosecution of the work, one (1) copy of said plans and specifications.

### TEST OF SAMPLES OF MATERIALS

All tests of materials will be made by the City in accordance with official approved methods as described or designated. The Contractor shall cooperate with and assist the Engineer in taking samples and packing them for shipment to a laboratory.

## **STORAGE OF MATERIALS**

Materials shall be stored so as to insure the preservation of their quality and fitness for the work. When considered necessary, they shall be placed on wooden platforms, or other hard, clean surfaces, and not on the ground, and shall be placed under cover when directed. Stored materials shall be located so as to facilitate prompt inspection. Lawns, grass plots, or other private property shall not be used for storage purposes without written permission of the owner or lessee.

## **QUALITY OF MATERIALS AND WORKMANSHIP**

All materials furnished and all work done in carrying out the contract shall be of the best quality and especially adapted to the services required. Wherever the characteristics of any materials are not particularly specified, such materials shall be used as is customary in first class work of the nature for which the material is employed. The source of supply and quality of each of the materials shall be approved by the Engineer before the delivery is started. Representative preliminary samples of the character and quality herein described shall be submitted by the Contractor when indicated or directed, for examination or test, and written approval of the quality of such samples shall be received by the Contractor prior to obtaining materials from the respective sources of supply. Only such materials as conform to the requirements of these specifications shall be used in the work. All materials proposed to be used may be inspected at any time during the progress of their preparation and use. All materials shall be approved before being incorporated in the work, and shall be new and unused.

Representative samples of all materials requiring laboratory tests shall be taken, and such materials shall be used only after written approval has been received by the representative of the Engineer in charge of the work, and only so long as the quality of said materials remains equal to requirements.

## **DIMENSIONS AND LEVELS**

The Contractor shall be solely responsible for construction of work at proper lines and elevations and no plans as to instructions or orders received from any source other than the information contained in the drawings or specifications, or in written orders of the Engineer, shall justify departure from the lines and elevations as shown on the plans.

## **MAINTENANCE, REPAIRS, ETC., AFTER COMPLETION**

The Contractor, at his entire cost and expense, shall maintain all portions of the work included in the contract to meet the requirements of these specifications for and during a period of three (3) months from and after the date of the conditional acceptance of the entire work by the City, and in addition, shall at his entire cost and expense, make all repairs and replacements of the work and appurtenances which may become necessary, in the judgment of the Engineer, at any time or times, during said three (3) months, on account of any failure or defects in said work and appurtenances due to improper work done or materials furnished by the Contractor.

## **DELINQUENT TAXES, ETC.**

The City shall have the right to set off against all monies due and payable under the provisions of this contract the sum representing the total amount of delinquent taxes and/or water sewer charges owed the City by the Contractor or any of its subcontractors. The monies so set off shall be credited to the amount shown by the tax and or water sewer records to be delinquent, said records shall be prima facie evidence of the true and correct amount of taxes and or water sewer charges due to the City.

The term "delinquent taxes" as used herein applies only to uncollected taxes, license fees, and penalties owed by the Contractor or subcontractor, a subsidiary, or principal owner thereof; "principal owner" as used herein is one which owns a majority share or otherwise maintains a controlling interest in the Contractor or subcontractor. The City shall notify the Contractor in writing of its intention to make the aforesaid set off. If the Contractor and the City cannot agree as to either the amount or propriety of the set off, a formal hearing shall be held. The scope of said hearing shall be limited to the Contractor's good faith objections as to the validity or propriety of the tax and/or water sewer assessment or contemplated set off. If the dispute remains extant, the amount subsequently set off shall be deemed paid under protest.



# **City of Wilmington DBE Program and Bidders Requirements**

## **DBE PROCUREMENT PROGRAM**

Responsibilities of the Equal Opportunity/Contract Compliance Office (EO/CCO) are assumed by the City of Wilmington's Small, Minority Business Enterprise Office (SMBEO) in the Mayor's Office of Economic Development. The City of Wilmington has established laws and procedures to increase accessibility of contracting opportunities for small and minority businesses. The EO/CCO authority derives from Chapter 35, Article IV of the Wilmington City Code. This section of the Code addresses Equal Opportunity in Employment and City Contracts.

Denita L. Thomas  
DBE Administrative Office  
Mayor's Office of Economic Development/SMBEO  
800 North French Street, 3<sup>rd</sup> Floor, Wilmington, DE 19801  
(302) 576-2121 (Office) • (302) 571-4326 (Fax)  
[www.WilmingtonDE.gov](http://www.WilmingtonDE.gov)

## DISADVANTAGED BUSINESS PROGRAM

In the performance of this contract, the contractor agrees to provide the information as described herein and to make its best efforts to include one or more types of disadvantaged businesses as subcontractors.

A Disadvantaged Business Enterprise means a business that is at least fifty-one percent (51%) owned and controlled by one or more socially disadvantaged individuals who, in fact, control the management and daily business operations of the business.

"Disadvantaged Individuals" are those who have been actual victims of discriminatory practices or individuals whose ability to compete in the free enterprise system has been impaired due to diminished capital and credit opportunities as compared to others in the same business who are not so disadvantaged.

In determining the degree of diminished credit and capital opportunities, the City may consider, but shall not be limited to, reviewing the assets and net worth of disadvantaged individuals and disadvantaged businesses.

For purposes of determining the disadvantage in competing for City contracts, there shall be a presumption of economic disadvantage if an individual's net worth, exclusive of up to one hundred and fifty thousand dollars (\$150,000.00) of equity in his or her primary residence, is less than five hundred thousand dollars (\$500,000.00). The City may, in the administration of its programs, direct its assistance toward those economically disadvantaged individuals who are among the chronically unemployed and may identify demographic subgroups of disadvantaged individuals identified by race or national origin whenever current, verifiable local statistics confirm the existence of unemployment rates among such individuals that are more than fifty (50) percent above the prevailing overall unemployment rate statewide.

All contractors doing business with the City shall show good faith efforts to obtain minority and other disadvantaged subcontracting businesses' participation. Good faith efforts shall be evidenced by listing each disadvantaged business enterprise (DBEs) contacted, showing the name and address of each, the names of contact persons, telephone numbers, sources used to identify DBEs, methods used to make contact, dates firms were contacted, responses, dates responses were received, type of subcontract, reasons for rejection if the firm is not used, and estimated value of each subcontract, through completion of the City's Form DBE-1.

The federal set-aside program requirements for any applicable federally funded contract are fully applicable to the City of Wilmington, such that contractors will be subject to federal penalties of non-compliance if a contract or any subcontract awarded involves the federal set-aside program and the contractor fails to meet its requirements as to that program.

## GOAL STATEMENT PROVISION FOR DISADVANTAGED BUSINESS PARTICIPATION

In order to expand opportunities and insure fair participation for disadvantaged individuals and businesses in its construction, goods and services and professional service contracts, the City has set purchasing goals for its fiscal year 1991 in each of these three procurement categories. Except to the extent that the Director of the Minority Business Office determines otherwise, such as for utilities, telephone, etc., the City shall endeavor to achieve, and shall require evidence of good faith efforts by bidders and contractors to achieve the goals of contracting with disadvantaged individuals or disadvantaged businesses for the following percentages of the total dollar amount of each contract in these three purchasing categories:

1. A goal of 20% for all construction contracts;
2. A goal of 10% for all professional service contracts; and
3. A goal of 5% for all goods and other contracts.

### Notes:

1. If the contractor customarily performs the work required in any subcontracting category by workers regularly employed by the contractor in his own organization, the contractor does not have to try to subcontract such work to others solely to comply with the DBE requirements. In such cases, however, the contractor shall clearly note this fact on the applicable DBE form(s), and the burden of proof shall be on the contractor to demonstrate the accuracy thereof upon inquiry by the City.
2. Female-owned businesses do **not**, per se, qualify as DBEs.
3. Questions regarding the DBE program should be directed to the City's EEO/Contractor Compliance Office at (302) 576-2121.
4. The City's DBE Directory can be assessed on line at [www.WilmingtonDE.gov](http://www.WilmingtonDE.gov) and click the link which reads "DBE Portal". Once at the welcome page click on "enter as a guest" to assess the DBE Directory.

## **ADDITIONAL GOOD FAITH EFFORT (CHANGES TO Chapter 35 of the City Code)**

Ordinance No. 09-057, effective December 1, 2009, requires the following DBE changes within the "Good Faith Efforts" in bidding regarding disadvantaged business enterprises (DBE's).

### **Subcontractors Listing**

Identify all subcontractors that the bidder plans to utilize as well as listing the amount of money that will be paid to each of the subcontractors as part of the contract

### **DBE Replacement**

Contractors are further required to make good faith efforts to replace any disadvantaged business enterprise ("DBE") that is terminated or has otherwise failed to complete its work on a contract. In such situations, the general contractor shall be required to notify immediately the City's DBE Office and provide reasonable documentation regarding any DBE's inability or unwillingness to perform the contracted work. The City's DBE Office shall require the general contractor to obtain prior approval for the DBE that will be used as a substitute, and the general contractor must provide copies of new or amended subcontracts along with documentation of the good faith efforts made in acquiring the substitute DBE.

### **DBE Payment**

General contractors shall pay all correct invoices for the completed work of any DBE subcontractor within 10 days of receipt by the prime contractor of payment by the City. Noncompliance with this section shall subject the general contractor to penalties as provided in Section 35-135(e).

The ordinance further provides administrative additional penalties for noncompliance in addition to the penalties already provided for in the Ordinance:

1. Suspension of contract;
2. Withholding of contract funds;
3. Termination of contract based on material breach;
4. Refusal to accept a future bid; and
5. Disqualification from eligibility for providing goods or services to the City for a period not to exceed 2 years.

## DBE FORMS

Contractors must file with the City, as applicable, the City's DBE Forms as follows:

1. **\*DBE-1:** A listing of the subcontractors included in the bid, by which a bidder acknowledges having read the DBE goal provisions in Attachment 1 and states that the bidder will expend a percentage of the dollar amount of the contract for DBE subcontractors, if any.
2. **\*DBE-2:** A listing of the subcontractors and other information to provide evidence of good faith efforts to include DBE's in subcontracts. This form must be completed and submitted with the bid, regardless of the level of DBE participation.
3. **\*DBE-3:** DBE verification form stating the ownership information regarding any business seeking to qualify as a City-certified DBE, if not listed in DBE Directory.
4. **DBE-4:** A DBE contract participation report requiring that the general contractor submit a report regarding DBE contract participation at the time the contract is entered into, when 50% and when 100% of each DBE subcontractor's portion of the construction project has been completed.
5. **\*DBE-5:** A listing of **ALL subcontractors** to be utilized on the contract. This form must be completed and submitted with the bid, regardless of the level of DBE participation.

### **FEDERAL Dollars involved in City Contracts:**

A DBE Utilization form(s), including reference to minority business enterprise participation if a federal program is involved, and an indication as to whether a disadvantaged business enterprise (DBE) status is claimed. These EPA (DBE Forms 6100-3 & 6100-4) forms are required by both the SRF and EPA Grant funding programs.

If you need additional information on the DBE Program or assistance completing the DBE Forms, please contact the office by one of the following methods:

Email: [dlthomas@WilmingtonDE.gov](mailto:dlthomas@WilmingtonDE.gov)

Phone: (302) 576-2121

Address: Small, Disadvantage Business Enterprise Office (SMBEO)  
Mayor's Office of Economic Development  
Louis L. Redding Building, 3<sup>rd</sup> Floor  
800 North French Street  
Wilmington, DE 19801  
City of Wilmington Website: [www.WilmingtonDE.gov](http://www.WilmingtonDE.gov)

---

\*Mandatory to be submitted back with Bid Documents.



## EFFORTS TO OBTAIN DBE SUBCONTRACTORS DBE FORM 1 – DBE FORM 2 EXPLANATION

[NOTE: DBE FORM-2 MUST BE COMPLETED BY ALL BIDDERS REGARDLESS OF THE LEVEL  
OF PARTICIPATION OF DBEs IN THE BID.]

All contractors doing business with the City are required to show good faith efforts to obtain DBE subcontracting businesses' participation. The burden is on the bidder to evidence such good faith efforts by means of the information required on this page. Failure to complete this form and/or failure to make good faith efforts to obtain DBE participation are grounds for rejecting any bid. Further, bidders are expected to make such good faith efforts to obtain DBE participation in connection with each and every subcontract, if any. The City's goals for DBE participation are listed on Attachment 1 to this form. These goals are not set-aside requirements, but they are the overall goals which the City is endeavoring to achieve through the disadvantaged business program. Each person or firm who or which submits a bid for City contracts is expected to demonstrate good faith efforts by actively and aggressively seeking out DBE participation in the contract to the maximum extent, to meet the City's goals, given all relevant circumstances, and shall complete all forms and follow guidelines as required by the Minority Business Office. The following are examples of the kinds of efforts that may be taken but are not deemed to be exclusive or exhaustive and the City's Minority Business Office may consider other factors and types of efforts that may be relevant:

1. Efforts made to select part of the work to be performed by DBEs in order to increase the likelihood of achieving the City's goal for that type of contract. Selection of parts of the work should at least equal the City's goal for DBE participation in that type of contract.
2. Written notification, at least ten (10) days prior to the opening of a bid, soliciting individual DBEs interested in participation in the contract as a subcontractor and for specific items of work.
3. Efforts made to negotiate with DBEs for specific items of work as detailed below and whether initial contacts to solicit DBE participation were followed up to determine with certainty whether DBEs were interested. A description of information provided to DBEs regarding plans and specifications and estimated quantities for parts of the work to be performed. A statement of why additional agreements with DBEs were not reached. Documentation of each DBE contacted but rejected and the reasons for the rejection.
4. Documentation that DBEs are not available or not interested.
5. Advertisements in general circulation media, trade association publications, and DBE media of interest in utilizing DBEs and specific areas of interest.
  - a. Efforts to use effectively the services of organizations that provide assistance in recruitment and placement of DBEs.
  - b. Whether the bidder selected portions of the work to be performed by DBEs in order to increase the likelihood of meeting the contract goals. This includes, where appropriate, breaking out contract work items into economically feasible units to facilitate DBE participation, even when the bidder might otherwise perform these work items with its own forces.

## DBE FORM 3 – DBE FORM 4 – DBE FORM 5 EXPLANATION

### DBE FORM 3

**DBE-3:** DBE verification form stating the ownership information regarding any business seeking to qualify as a City-certified DBE.

- This form must be submitted back with the bid when the contractor is working with a company who they believe to be eligible for the City of Wilmington's DBE Program. The SMBEO Office reserves the right to determine the eligibility and verification of eligibility for the firm listed on DBE Form 3.
- The burden is on the bidder to evidence such good faith efforts by means of providing the contact information for the DBE firm listed on the DBE Form 3. If a firm is determined to be an eligible DBE firm, the total dollar value of the participation by the DBE will be counted toward the contract requirement. The total dollar value of participation by a certified DBE will be based upon the value of work actually performed by the DBE and the actual payments to DBE firms by the Contractor.
- Failure to complete the DBE 3 form and/or failure to make good faith efforts to obtain DBE participation are grounds for rejecting any bid.

### DBE FORM 4

**DBE-4:** DISADVANTAGED BUSINESS ENTERPRISE – CONTRACT PARTICIPATION REPORT

- The Contractor shall provide the DBE Office with an accounting of payments made to Disadvantaged Business Enterprise firms, including material suppliers, contractors at all levels (prime, subcontractor, or second tier subcontractor). This accounting shall be furnished to the DBE Office when the contract is entered into by the general contractor and the subcontractor, when 50% and when 100% of each DBE subcontractor's portion of a project has been completed. Failure to submit this information accordingly may result in the following action or other action as deemed by the City:
  1. Withholding of money due in the next partial pay estimate; or
  2. Contractor may be disqualified from further bidding for a period as designated.

### DBE FORM 5

**DBE-5** SUBCONTRACTORS' REPORT

- The Contractor shall provide the DBE Office with a listing of ALL sub contractors to be entered into contract with this bid. DBE subcontractor(s) are not to be listed on this form but on form DBE #1 (Ord. 09-057).
- Failure to complete the required Subcontractor's form (DBE Form 5) will be grounds for the disqualification of such bid as being a responsive bid.

**To Be Submitted with Bid**

CONTRACT: \_\_\_\_\_

FORM DBE-1  
(Rev. 10/09)

*Failure to submit this completed form will be cause for rejection of your proposal*

Bidder acknowledges that he has read the D.B.E. goal provisions of the City for this fiscal year and that bidder will expend the dollar amount of the contract for D.B.E. subcontractors through the use of the following disadvantaged business enterprises, subject to the certification by the City, as subcontractors and that Bidder has made good faith efforts\* as evidenced by its listing of disadvantaged businesses that were contacted as detailed herein and on the following pages. (Must be completely filled out.)

**CITY OF WILMINGTON  
DISADVANTAGED BUSINESS ENTERPRISE ("D.B.E.")  
SUBCONTRACTOR LISTING**

DBE Firm Name (Firm Number)	Mailing Address & Contract Number	Type of Service	Dollar Amount of Contract
Total Dollar Amount to be Expended for Disadvantaged Business Enterprises			
Total Amount of Contract			
Percentage of Contract used for D.B.E.			

\_\_\_\_\_ Name of Authorized Official of Bidder Title

\_\_\_\_\_ Company

\*Good faith efforts shall be evidenced by listing each and every disadvantaged business enterprise (DBEs) contacted, showing the name and address of each, the names of contact persons, telephone numbers, sources used to identify DBEs, methods used to make contact, dates firms were contacted, responses, dates responses were received, type of subcontract, reasons for rejection, and estimated value of subcontract.

**To Be Submitted with Bid**

CONTRACT: \_\_\_\_\_

FORM DBE-2  
(Rev. 10/09)

*Failure to submit this completed form will be cause for rejection of your proposal*

DBE Firm Name/Address	Contact Person(s) Email or Phone Number	Date Contacted Initially and in Follow Up Methods Used	Type of Subcontractor plus Estimated Value	Reason for Rejection (If Firm Not Used) (If Bid "Too High" Also Indicate Value)
1.				
			\$	
2.				
			\$	
3.				
			\$	

Were advertisements placed in general circulation media, trade association publications, and DBE media interested in DBE participation? If so, state details of the advertisement. If not, state why not.

What efforts were made to use the services of organizations that provide assistance in recruitment and placement of DBEs?

The following are examples of actions that may not be used as justification by the contractor or bidder for failure to meet DBE participation goals:

1. Failure to contract with a DBE solely because the DBE was unable to provide performance and/or payment bonds.
2. Equipment idled by contract with DBE.
3. Rejection of a DBE because of its union or non-union status.

If more DBE firms have been contacted, please list with supplemental form(s) on additional pages.

**To Be Submitted with Bid if DBE is not listed in City DBE Directory**

CONTRACT: \_\_\_\_\_

FORM DBE-3  
(Rev. 10/09)

*Failure to submit this completed form will be cause for rejection of your proposal*

**CITY OF WILMINGTON  
DISADVANTAGED BUSINESS REGISTRATION VERIFICATION FORM**

1.	NAME:		
2.	ADDRESS:		
3.	PHONE:	PRODUCT OR SERVICE LINE:	
4.	TYPE OF FIRM: <input type="checkbox"/> Corporation <input type="checkbox"/> Partnership <input type="checkbox"/> Individual <input type="checkbox"/> Other _____		
5.	EMAIL:		
6.	DATE OF ORIGATION OF FIRM:	EMAIL:	
7.	BUSINESS LICENSES HELD:	City:	State: Other:
8.	DISADVANTAGED OWNERSHIP OF FIRM:		
	<b>NAME</b>	<b>OWNERSHIP OF FIRM</b>	<b>DISADVANTAGED</b>
a.			
b.			
c.			
d.			
e.			
f.			
9.	NON-DISADVANTAGED OWNERSHIP OF FIRM:		
	<b>NAME</b>	<b>OWNERSHIP OF FIRM</b>	
a.			
b.			
c.			
d.			
e.			
f.			
8.	I hereby certify that the information above is true and complete to the best of my knowledge and belief, and that I have been duly authorized to make this certification on behalf of the firm.		

NAME (printed) \_\_\_\_\_

SIGNATURE \_\_\_\_\_

DATE \_\_\_\_\_

TITLE \_\_\_\_\_

FOR OFFICE USE ONLY

DATE RECEIVED: \_\_\_\_\_  
DATE APPROVED: \_\_\_\_\_  
INFORMATION VERIFIED: \_\_\_\_\_

The General Contractor is required to submit this Compliance Report to the Disadvantaged Business Development Officer, City/County Building, 3<sup>rd</sup> Floor, 800 French Street, Wilmington, Delaware 19801, when the contract is entered into by the general contractor and the subcontractor, when 50% and when 100% of each DBE subcontractor's portion of a construction project has been completed.

**DISADVANTAGED BUSINESS ENTERPRISE  
CONTRACT PARTICIPATION REPORT**

1. Contract No. \_\_\_\_\_ Amount of Contract \$ \_\_\_\_\_
2. Name of General Contractor: \_\_\_\_\_
3. Address: \_\_\_\_\_
4. E-Mail Address: \_\_\_\_\_
5. The above-named contractor intends to fulfill its commitment to expend \$ \_\_\_\_\_  
(\_\_\_\_%), of its contract with Disadvantaged Business Enterprises ("DBEs"). The following year-to-date expenditure(s) has been made with a DBE Subcontractor(s):

Name/Address of DBE Subcontractor	Nature of Participation	Dollar Value/Percentage Participation	Dollar Amount Expended to Date
1.			
2.			
3.			

CONTRACT COMPLETION DATE: \_\_\_\_\_

\_\_\_\_\_  
General Contractor

\_\_\_\_\_  
Name of Authorized Officer

\_\_\_\_\_  
Date

\_\_\_\_\_  
DBE Subcontractor

\_\_\_\_\_  
Signature of Authorized Officer

\_\_\_\_\_  
Date

<b>Office Use Only (Prime)</b> Payment Received: _____ Amount: _____ Date: _____ Payment Received: _____ Amount: _____ Date: _____
--

\_\_\_\_\_  
City of Wilmington

\_\_\_\_\_  
Date

\_\_\_\_\_  
Contract Compliance Officer's Name

\_\_\_\_\_  
City of Wilmington

\_\_\_\_\_  
Date

\_\_\_\_\_  
Contract Compliance Officer's Signature

CONTRACT: \_\_\_\_\_

FORM DBE-5  
(Rev. 10/09)

*Failure to submit this completed form will be cause for rejection of your proposal*

**CITY OF WILMINGTON  
SUBCONTRACTOR LISTING**  
(Do not include DBE Firms to be utilized)

Subcontractor Name IRS Numbers	Mailing Address Contact Number/ Email	Type of Service	Dollar Amount of Contract
Total Dollar Amount to Non-Disadvantaged Business Enterprises			
Total Amount of Contract			

Bidder acknowledges that he has identified all sub contractors that will be utilized as well as listing the amount of money that will be paid to each of the subcontractors as part of the contract (use additional pages if necessary).

\_\_\_\_\_ **Name of Authorized Official of Bidder**

\_\_\_\_\_ **Title**

\_\_\_\_\_ **Company**

\_\_\_\_\_ **Date**

## 16010PW - SEWER CONSTRUCTION

### I. GENERAL

This sewer infrastructure maintenance contract is for any work on the sanitary, storm, and/or combined sewer system and miscellaneous projects within the City of Wilmington, Delaware.

### II. DESCRIPTION

This Contract is for the installation and emergency repair of sewer branches within City of Wilmington right-of-way, sewer extensions, main sewer repair/installation, construction of new manholes, construction of lamp holes, and miscellaneous structures relating to sewer construction in the City of Wilmington. This is a maintenance Contract in nature, with work spread out during the fiscal year on an "as needed" basis, based upon service demand.

This maintenance contract will be for a period of one (1) year, starting on July 1, 2015 and ending on June 30, 2016. The City of Wilmington may extend the contract for two (2) additional one (1) year periods (renewal option). The City of Wilmington will provide written notification to the vendor if there is a desire to exercise either of these one year renewal options. This notification will take place at least 60 days prior to the current expiration date. The City of Wilmington may allow price escalation at the time of renewal in an amount not to exceed 2% of the original contract amount. The actual escalation percentage allowed if any will be at the sole discretion of the City of Wilmington.

### III. SPECIFICATIONS

- A. All construction must be done in compliance with the "Occupational Safety and Health Act" of 1970 and all rules and regulations thereto appurtenant.
- B. The chart, Appendix A, represents minimum trench shoring requirements that must be utilized on all trenches.
- C. The bidder shall document that they are capable of actively handling a minimum of four (4) projects at one time in the construction phase. It is estimated that 90% of the work will require only one crew. The four projects capability may be waived on a case-by-case situation (depending on the complexity of the projects) with written permission of the Engineer if it places an unusual burden on the Contractor's present workload.
- D. All bids must be responsive and balanced. Any unbalanced bids shall be rejected at the discretion of the City of Wilmington.



- E. Bidder shall furnish the name and qualification of the general superintendent and his 24-hour contact phone number whose responsibility it will be to oversee all work for the City. This general superintendent may not be replaced without prior permission from the City.
- F. Per City Code, the Contractor and/or Subcontractor must have a trade license for plumbing and business license with the City of Wilmington.
- G. Bidder shall insure that a crew shall have appropriate equipment and personnel available for work, twenty-four (24) hours per day, seven (7) days per week. The Contractor shall start emergency repair projects within two (2) hours verbal notice by an authorized representative of the Department of Public Works, City of Wilmington. Emergency repair projects and/or work not covered by the contract shall be completed on a force account basis unless the parties mutually agree otherwise.
- H. All trenches shall be restored with clean fill. The Contractor will restore roadway in accordance with City of Wilmington Road Cut Specification/DelDOT Specifications.
- I. A separate contract pay item has been included for the mechanical saw cut. All trenches and excavations shall be neatly saw cut with the finished paving patch true and flush. Any street patch not installed to the satisfaction of the Engineer shall be removed, re-cut, and replaced at the Contractor's expense.
- J. The following pavement cross sections shall be used:
  - a. Hot Mix Surfaced Roadway: 8-12 inches Class B concrete base course, (City) or Class A concrete base course (State) 2 inches of hot mix type C.
  - b. Concrete Roadway: 10-12 inches Class A concrete, reinforced with WWF 66 x 44 wire mesh.

- K. Polyvinyl Chloride pipe (PVC) shall be used on each project unless another type pipe is specified by the Engineer. This pipe will be suitable for non-pressure drainage of sewage and surface water. The pipe shall conform to ASTM Designation: D 3033, Type PSP or D 3034, Type PSM. The SDR number which expresses the ratio of pipe diameter to wall thickness that will be acceptable is SDR-26 and Schedule 40. The Engineer has the authority to specify the desired SDR number, or pipe schedule for each individual project. All fittings and saddles shall be made of PVC plastic and will be subject to the approval of the Engineer. Ferncos will have to be approved by the City representative. The two joining systems are:
- a. Solvent Cement Joints: The pipe spigot wedges into the tapered socket and the two surfaces fuse together.
  - b. Elastomeric Gasket Joints: Assembly shall be in accordance with pipe manufacturer's recommendation.

#### IV. CONTRACTOR RESPONSIBILITIES

The awarded Contractor shall be responsible for the requirements, specific to this contract, as outlined below.

- A. All castings shall be supplied by the City at no cost to the Contractor. If the City does not have these items in stock, the City has the option to require the Contractor to furnish the item and charge the City for this item or have the item supplied by the Contractor and the City return the item to the Contractor at a later date.
- B. Contractor to furnish all backfill and restoration materials. Contractor has to be familiar with State and City specifications and have current licenses for applicable work, (i.e., blasting, repaving, sidewalks, etc.)
- C. Contractor shall work under direction of a City representative. The City shall have complete discretion as to the sequence and priority of the work. The City will secure State street opening permits and inform applicable City departments as to schedule of work if required. Contractor has to work in accordance with permits and applicable City procedures.
- D. Traffic Control Devices shall be provided by the Contractor and charged according to the rates listed on the proposal form. The Contractor shall have barricades and signs picked up as soon as roadway work is completed.
- E. All road cuts and restorations shall comply with the City's Road Cut Management System's (RCMS) requirements for City maintained roads and DeIDOT requirements for State maintained roads. The Contractor shall notify the Engineer upon starting work to determine which permit must be obtained.

F. The Contractor shall be responsible to notify the following utilities before commencing work:

- (1) Delmarva Power (Gas)
- (2) Verizon
- (3) Delmarva Power (Electric)
- (4) Wilmington Department of Public Works, Water and Sewer Divisions
- (5) Fiber Optic Companies

Extreme caution shall be exercised by the Contractor at all times. Any damage caused to existing utility lines, conduits, etc., directly or indirectly, shall be repaired immediately at the Contractor's expense.

Miss Utility of Delaware shall be notified at 1-800-282-8555.

G. The Contractor shall erect and maintain suitable barricade protection and signs for public safety throughout the project and provide sufficient walking areas and travel ways where required. All barricades shall be mounted with dual, yellow flashing battery-powered lights.

Construction signing and maintenance of traffic shall conform to the "Manual on Uniform Traffic Control Devices for Streets and Highways" published by the U.S. Department of Transportation, Federal Highway Administration.

H. The Contractor shall keep the trench to a maximum width of five feet (5') unless otherwise instructed by the Engineer. Any material excavated in excess of this limit shall be replaced at the Contractor's expense unless approved by engineer. All trench walls shall be well supported at all times at the expense of the Contractor. The City will pay the Contractor for trench wall support only when the sewer project is completed on a force account (time and material) basis.

I. Existing sewer lines must be kept free and clear of obstruction and debris at all times; nor shall any part of the construction site be left in an offensive or unsanitary condition. If dirt, construction material, or any other debris enters the sewer line during the construction of the individual project, the Contractor will be required to clean the sewer line, at his expense, to the satisfaction of the Engineer/Inspector.

J. The Contractor shall remove all unsuitable materials from the job site and dispose of same to the satisfaction of the Engineer. This will be done at the Contractor's expense unless work is being done under force account basis or contaminated soils are involved. Select backfill or approved fill shall be used to replace unsuitable material.

- K. The Contractor and/or his subcontractor shall verify all measurements daily and include on Daily Work Authorization for Itemized Projects. No extra compensation shall be allowed unless approved by the Engineer in writing before proceeding with the work.
- L. The Contractor shall guarantee all work for a period of one (1) year. Any defects appearing before this time shall be repaired upon demand by the City of Wilmington.
- M. Each project under this Contract shall be completed within 10 working days, unless otherwise specified by the Engineer. The owner shall deduct three hundred (\$300) dollars for each and every day beyond the allowed time that is required to complete the project. Liquidated damages are not to be construed in any sense as a penalty.
- N. The Contractor shall post "No Parking" signs at the construction site twenty-four (24) hours prior to commencing with the work. "No Parking" signs shall be supplied by the Department of Public Works at no cost to the Contractor.
- O. All available sewer information on existing lines in the City of Wilmington shall be supplied by the Department of Public Works at no cost to the Contractor. The Contractor will be supplied with plans for each project. Detail plans of standard manholes, sewer inlets, and lamp holes to which the Contractor has to conform on all the projects, shall be supplied to the Contractor by the City.
- P. The Contractor shall meet with the property owners' plumbing contractor prior to construction in order to ascertain the exact location and grade of a new lateral at the curb. The Contractor shall construct new laterals or sewer branches to the curb only or within the City of Wilmington right-of-way.

## V. Method of Payment

Individual projects assigned by the Engineer shall be paid for at the unit price bid for each item. Payment shall be made for individual construction projects upon inspection and acceptance by the Department of Public Works. The provisions of the General Conditions pertaining to work performed on a "force account" basis will be modified in this section. All work done by "force account" will be paid for in the following manner:

### A. Labor

1. Shall be in accordance with unit pricing on the proposal form
2. The contractor, upon approval by the City, may utilize and bill for overtime hours to perform work related to this contract in accordance with the following conditions:
  - a. Overtime hours shall be defined as any hours outside of the regular workday as described herein. The regular workday shall consist of eight (8) hours (plus ½ hour for lunch breaks) and the workweek shall consist of forty (40) hours (plus 2½ hours for lunch breaks, per week) Monday through Friday inclusive.
  - b. Time and one-half shall be paid for hours worked in excess of eight (8) hours in any continuous twenty-four (24) hour period or in excess of forty (40) hours per workweek.
  - c. Time and one half shall be paid for work performed on Saturday and double time for work performed on Sunday and holidays. Contractor shall furnish a list of the company's observed holidays with its bid.
  - d. Work prior to or beyond the contractor's regular starting and quitting time shall be compensated at the rate of time and one half. The hours for a regular workday for this contract shall be submitted with the proposal forms.
3. For all laborer classification not included in the contract, the contractor and the City shall mutually agree on rates to be used.

- ### B.
- Contractor to furnish the City's representative with daily copy of labor and equipment time sheets (daily work authorizations (DWA)) and copy of delivery receipts for Contractor's furnished materials. The DWAs shall be signed by a City inspector, each day, with carbon copies provided to the Engineer.

- C. The Contractor is to bill the City every other week for work that has occurred in that time frame. The Contractor shall provide electronic copies of the invoices to the City's Finance Department, Accounts Payable, and hard copies to the Department of Public Works.
- D. Mobilization/Demobilization: The cost for mobilization and demobilization shall be included in the bid items for Itemized and Force Account Projects. There will be no separate billing for mobilization and demobilization or extra hours.
- E. The bidder shall fill out the supplemental equipment rental schedule included on the proposal forms. These items are not included in the totals used for the evaluation of bids; however, the City may request clarification for any rates that are excessive when compared with other qualified bidders. If the Contractor uses any equipment on a job site, which is not listed on the proposal forms, the Contractor shall request approval for the rates by the City's Representative before use of the equipment. Materials furnished by the Contractor will be charged at cost, plus 10%. Cost will be supported by vendor's invoice.
- F. Before employing a subcontractor, the Contractor shall request written approval from the City by submitting subcontractor information as outlined in Construction Contracts General Conditions.
- G. For administrative costs in connection with approved subcontract work, the contractor shall receive an amount equal to 5% of the total cost of such work computed. The City will not pay for a subcontractor for equipment, personnel, or material that has been specified in the contract.
  - 1. Approved subcontracted services will be charged at Cost, plus 5%. Cost shall be supported by subcontractor's invoice.
- H. On Item #4, ROCK EXCAVATION, Rock excavation shall consist of the removal and final disposal of all hard ledge rock and boulders of more than 1/3 cubic yard in volume, as determined by the Engineer. Rock Excavation shall not include soft or disintegrated rock, bituminous surface treatment, gravel, broken stone, slag, cobblestones, or any material which can be removed by ordinary power equipment or hand methods, but shall be confined to materials so hard and firmly cemented that in the opinion of the Engineer, it is not practicable to excavate or remove except after drilling, splitting, and/or wedging. The price and payment shall be full compensation for furnishing all equipment, tools, labor, and incidentals necessary to complete the item.
- I. Materials. For materials accepted by the Engineer and used, the contractor shall receive the actual cost of such materials delivered on the work, including transportation charges paid by him/her (exclusive of machinery rentals as hereinafter set forth), to which cost 10% will be added.

- J. Statements shall be accompanied and supported by invoices for all materials used and transportation charges. However, if materials used on the force account work are not specifically purchased for such work but are taken from the contractor's stock, then in lieu of the invoices the contractor shall furnish an affidavit certifying that such materials were taken from his stock, that the quantity claimed was actually used, and that the price and transportation claimed represent the actual cost to the contractor. If unit measurement is by weight, certified weight slips will be required.
- K. Equipment. Payments for equipment shall be in accordance with unit prices in the proposal form and supplemental equipment form. For any other machinery or special equipment (other than small tools) including fuel and lubricants, plus transportation costs not included on the proposal form or supplemental equipment form, and the use of which has been authorized by the Engineer, the contractor shall receive the rental rates agreed upon in writing before such work is begun for the actual time that such equipment is in operation on the project, to which rental sum 10% will be added. Rates may be revised using the Rental Rate Blue Book for Construction Equipment as a guide for determining the rates.
- L. The bidder shall fill out the supplemental equipment form included with proposal forms. These items are not included in the totals used for the evaluation of bids; however, the City may request clarification for any rates which are excessive when compared to other qualified bidders or the rental rate blue book. If the contractor uses any equipment on a job site which is not listed on the proposal form, the contractor shall request approval for the rates by the City's representative.
- M. Miscellaneous. No additional allowances will be made for general superintendent, the use of small tools, or other costs for which no specific allowance is herein provided.
- N. Compensation. The contractor's representative and the Engineer/Inspector shall compare records daily of the cost of work done as ordered on a force account basis.
- O. All hot mix paving will be performed by the Contractor unless otherwise specified by an authorized representative.
- P. Pipe-in-place shall be paid at unit price bid per linear foot. Price and payment shall include full compensation for furnishing, transport, and placing all materials for all labor, equipment, tools, and miscellaneous structures including reducers (P.V.C.P.), 1/8 bends, saddles, 1/4 bends, etc., to connect to existing main sewer lines.

- Q. Item 16 (with the exception of 16A2-Manholes) price and payment shall include full compensation for furnishing, transport, installing, and placing all materials for all labor, equipment, tools, and miscellaneous structures. Excavation & Removal, Roadway Restoration, and Saw cutting will be paid for separately per bid items in contract. These items will be the same for City-maintained or State-maintained highways, streets, and sidewalks.
- R. Item 16A2-Manholes price and payment shall include full compensation for Excavation & Removal, Roadway Restoration, Saw cutting, transport, furnishing, installing, and placing all the material, for all labor, equipment, tools, and miscellaneous structures. This item will be the same for City-maintained and State-maintained highways, streets, and sidewalks.
- S. All item numbers in Section I price and payment shall include full compensation for furnishing, transport, installing, and placing all materials including all labor equipment, and tools. These items shall remain the same for City-maintained and state-maintained roads, highways, and sidewalks.
- T. Exceptions to the Construction Contracts General Conditions:
1. Force Account Work: Unless otherwise agreed to in writing by the City and the Contractor, all Force Account Work shall be paid according to the prices listed on the proposal forms and the designated materials and subcontractor mark-ups listed in the Specifications.
  2. Maintenance of Traffic: The contractor shall conform to all State and City regulations/requirements governing maintenance of traffic.
  3. Partial Payment: Unless otherwise agreed to in writing by the City and the Contractor, the City will not withhold 10% from payment requests submitted by the Contractor.
  4. Last Payment to Terminate Liability of Owner: Any invoices not submitted within 3 months of the last day of the yearly contract shall not be paid by the City. Conditional Acceptance/Final Acceptance of Payment: Unless otherwise agreed to in writing by the City and the Contractor, this section shall not apply to this contract.
  5. Night Weekend and Holiday Work: The Contractor shall be required to work night weekend and holiday work at the verbal or written request of the Engineer or other City representatives as designated by the Engineer. The contractor will not be required to reimburse the City for Construction Inspectors and their related expenses. The Contractor will be compensated as described in the Specifications.



6. Hours of Labor: The Contractor and their employees shall be permitted to work greater than 8 hours of work in one calendar day as necessary to complete necessary work and safely secure each job site.
7. Wages Payable Under Municipal Contracts, Etc.: Highway Wage Rates as defined by the State Department of Labor shall be considered the Prevailing Wage Rate applicable to this contract.
8. Final Restoration: In all cases where pavement restoration is required, the Contractor will be responsible for restoration according to City or State Road Inspector/ Engineer designation and/ or according to applicable standards.

Should the contractor refuse or fail to prosecute the work as directed or to submit its claim as required, the Engineer may withhold payment on all current estimates relating to a disputed claim until the contractor complies with these requirements or, after giving the contractor due notice, the Engineer may make payment for said work on the basis of a reasonable estimate of the value of the work performed.

Work At or Near Known or Suspected Contaminated Sites: See Special Provisions

Protection of Trees Within Project Limits: See Special Provisions

Sample Invoice: The attached invoice is a sample of the information required for invoicing. See Special Provisions

DEPARTMENT OF PUBLIC WORKS  
WILMINGTON, DELAWARE

PROPOSAL FORM

16010PW- SEWER CONSTRUCTION

DATE: \_\_\_\_\_

Our City of Wilmington Business License is Number \_\_\_\_\_.

This Proposal is submitted with the knowledge that the Department of Finance, Procurement and Records Division, reserves the right to reject any and all proposals when in its judgment is it in the best interest of the City of Wilmington to do so.

We, the undersigned, hereby agree to furnish and deliver, per specifications, the item(s) listed below to the Department of Public Works, Wilmington, Delaware.

**Section I** -- The estimated items below will be used as the method of payment for the Scope of Work stated in the General Requirement section of the specifications.

<u>ITEM NO.</u>	<u>APPROXIMATE QUANTITY AND DESCRIPTION</u>	<u>UNIT PRICE</u>	<u>TOTAL PRICE</u>
Item 3	<u>EXCAVATION &amp; REMOVAL:</u>  2000 Cubic yards at _____ Dollars and _____ Cents per cubic yard.	(\$ _____)	\$ _____
Item 4	<u>ROCK EXCAVATION:</u>  40 Cubic yards at _____ Dollars and _____ Cents per cubic yard.	(\$ _____)	\$ _____
Item 6A	<u>SELECT BORROW:</u>  1,000 Tons at _____ Dollars and _____ Cents per ton.	(\$ _____)	\$ _____

<u>ITEM NO.</u>	<u>APPROXIMATE QUANTITY AND DESCRIPTION</u>	<u>UNIT PRICE</u>	<u>TOTAL PRICE</u>
Item 6B	<u>CRUSHER RUN (CR-1):</u>  500 Tons at _____ Dollars and _____ Cents per ton.	(\$ _____)	\$ _____
Item 6C	<u>106A STONE:</u>  200 Tons at _____ Dollars and _____ Cents per ton.	(\$ _____)	\$ _____
Item 6D	<u>TOPSOIL</u>  3 Tons at _____ Dollars and _____ Cents per lineal feet.	(\$ _____)	\$ _____
Item 6E	<u>RECYCLED/CRUSHED CONCRETE:</u>  500 Tons at _____ Dollars and _____ Cents per lineal feet.	(\$ _____)	\$ _____
Item 9	<u>P.C.C. BASE COURSE:</u>  #9A-Class A Portland Cement Concrete 30 Cubic Yards at _____ Dollars and _____ Cents per cubic yard.	(\$ _____)	\$ _____
	#9B-Class B Portland Cement Concrete 560 Cubic Yards at _____ Dollars and _____ Cents per cubic yard.	(\$ _____)	\$ _____
Item 10	<u>HOT MIX C</u>  10A-Hot Mix 300 Tons at _____ Dollars and _____ Cents per ton.	(\$ _____)	\$ _____
	10B-Cold Patch 50 Tons at _____ Dollars and _____ Cents per ton.	(\$ _____)	\$ _____

<u>ITEM NO.</u>	<u>APPROXIMATE QUANTITY AND DESCRIPTION</u>	<u>UNIT PRICE</u>	<u>TOTAL PRICE</u>
Item 15	<u>SEWER CONSTRUCTION:</u>		
	#15A-6-inch P.V.C. Pipe 600 Lineal Feet at _____ Dollars and _____ Cents per lineal foot.	(\$ _____)	\$ _____
	#15B-8-inch P.V.C. Pipe 300 Lineal Feet at _____ Dollars and _____ Cents per lineal foot.	(\$ _____)	\$ _____
	#15C-10-inch P.V.C. Pipe 300 Lineal Feet at _____ Dollars and _____ Cents per lineal foot.	(\$ _____)	\$ _____
	#15D-12-inch P.V.C. Pipe 200 Lineal Feet at _____ Dollars and _____ Cents per lineal foot.	(\$ _____)	\$ _____
	#15E-16-inch P.V.C. Pipe 100 Lineal Feet at _____ Dollars and _____ Cents per lineal foot.	(\$ _____)	\$ _____
	#15F-18-inch P.V.C. Pipe 100 Lineal Feet at _____ Dollars and _____ Cents per lineal foot.	(\$ _____)	\$ _____
Item 16	<u>STRUCTURES (REPAIR AND INSTALLATION):</u> (All castings supplied by City)		
	#16A-Brick Manhole 300 Vertical Feet at _____ Dollars and _____ Cents per vertical foot.	(\$ _____)	\$ _____
	#16A2-Manholes (replace lid and frame assembly only) 20 each of _____ Dollars and _____ Cents each.	(\$ _____)	\$ _____
	#16A3-Pre-cast Reinforced Concrete Manholes 200 Vertical Feet at _____ Dollars and _____ Cents each.	(\$ _____)	\$ _____

<u>ITEM NO.</u>	<u>APPROXIMATE QUANTITY AND DESCRIPTION</u>	<u>UNIT PRICE</u>	<u>TOTAL PRICE</u>
	#16B-Lamphole 4 Each at _____ Dollars and _____ Cents each.	(\$ _____)	\$ _____
	#16C-Install, Repair and Restore (paring catch basin walls) Catch Basin Type "A" or "I" 160 Vertical Feet at _____ Dollars and _____ Cents per vertical foot.	(\$ _____)	\$ _____
	#16D-Install, repair, and restore (paring catch basin walls) double Catch Basin Type "A" or "I" 60 Vertical Feet at _____ Dollars and _____ Cents per vertical foot.	(\$ _____)	\$ _____
Item 19	<u>Curb 19A-PORTLAND CEMENT CURB</u>		
	120 Lineal Feet at _____ Dollars and _____ Cents per lineal foot.	(\$ _____)	\$ _____
	<u>19B-GRANITE CURB</u>		
	20 Lineal Feet at _____ Dollars and _____ Cents per lineal foot.	(\$ _____)	\$ _____
Item 20	<u>PORTLAND CEMENT CONCRETE SIDEWALK:</u>		
	4-inch Thick Sidewalk 800 Square Feet at _____ Dollars and _____ Cents per square foot.	(\$ _____)	\$ _____
Item 35	<u>CUT-INS (CORE-DRILLED):</u>		
	#35A*-100 Cut-Ins at _____ Dollars and _____ Cents each.	(\$ _____)	\$ _____
	#35C-Mechanical Saw Cut 2,100 Lineal Feet at _____ Dollars and _____ Cents per lineal foot.	(\$ _____)	\$ _____

**Year 1 – Subtotal of All Items Listed for Section I**    \$          

\* The “cut-in” item (#35A) appearing on the Proposal Form, includes connecting to the main line and manholes where specified. In addition, all cut-ins must be core-drilled.

**Section II** – The items below will be used as a method of payment for work not covered by the items in Section I and for force account work. This section will be estimated for a time period of 120 days.

Bricklayer (1)	8 hour/day @	\$ _____	=	\$ _____
Working Foreman (1)	8 hour/day @	\$ _____	=	\$ _____
Laborer (1)	8 hour/day @	\$ _____	=	\$ _____
Radio Pick-Up Truck (1)	8 hour/day @	\$ _____	=	\$ _____
Pick-Up/Tool/Crew Truck (1)	8 hour/day @	\$ _____	=	\$ _____
Air Compressor w/Tools (125 CFM) (1)	4 hour/day @	\$ _____	=	\$ _____
2" – 3" Submersible Pump	4 hour/day @	\$ _____	=	\$ _____
Dump Truck (Single Axle)	8 hour/day @	\$ _____	=	\$ _____
Dump Truck (Tri Axle)	8 hour/day @	\$ _____	=	\$ _____
Trackhoe (5/8 to ¾ yard)	8 hour/day @	\$ _____	=	\$ _____
Flagger	8 hour/day @	\$ _____	=	\$ _____
Flatbed/ Stake body or Winch Truck	8 hour/day @	\$ _____	=	\$ _____
Tractor Truck w/ Lowboy Trailer	2 hour/day @	\$ _____	=	\$ _____
Tamper (Gas) (1)	2 hour/day @	\$ _____	=	\$ _____
Road Sign (1)	each per day @	\$ _____	=	\$ _____
Barrels/Barricades/Cones (1)	each per day @	\$ _____	=	\$ _____
Driver (1)	8 hour/day @	\$ _____	=	\$ _____
Equipment Operator (1)	8 hour/day @	\$ _____	=	\$ _____
Backhoe/Loader (1)	8 hour/day @	\$ _____	=	\$ _____
Trailer/Boom Truck (1)	2 hour/day @	\$ _____	=	\$ _____
Trench Shoring (5 ft.-10 ft. depth)	8 hour/day @	\$ _____	=	\$ _____
Backhoe w/Hydro Hammer	4 hour/day @	\$ _____	=	\$ _____
Steel Road Plate (1)	each per day @	\$ _____	=	\$ _____
Arrow Board (1)	8 hour/day @	\$ _____	=	\$ _____
Pipe Saw/Chain Saw (1)	2 hour/day @	\$ _____	=	\$ _____
Large Paving Saw (Walk Behind) (1)	2 hour/day @	\$ _____	=	\$ _____
Paving Roller (1)	2 hour/day @	\$ _____	=	\$ _____
Cement Finisher	8 hour/day @	\$ _____	=	\$ _____

**Subtotal of all items listed for Section II times 120 days \$ \_\_\_\_\_**

**Section III-** The items below will be used as a method of payment for work not covered by the items in Section I and Section II for force account work. This section will be estimated for a time period of 30 days.

Sewer Jet/ Vacuum Truck            4 hour/day @    \$ \_\_\_\_\_ = \$ \_\_\_\_\_

**Subtotal of all Items above in Section III times 30 days = \$ \_\_\_\_\_**

**Grand Total:**

**Subtotal Section I + Subtotal Section II + Subtotal Section III =  
\$ \_\_\_\_\_**



Supplemental Equipment for Force Account Work (only) (not to be calculated with bid prices).

<u>Item</u>	<u>Proposal Substitution</u>	<u>Rate Type</u>	<u>Unit Price</u>
Welding Rig	_____	Hourly	_____
Water Truck	_____	Hourly	_____
Nu-Mo Gopher	_____	Hourly	_____
Air Drill	_____	Hourly	_____
Small Paving Hand Saw	_____	Hourly	_____
Generator (2,500 W)	_____	Hourly	_____
Tri-Pod Work Light	_____	Hourly	_____
Electric Sump Pump	_____	Hourly	_____
Rammax Compactor	_____	Hourly	_____
Mueller Tap Machine 3/4" - 2"	_____	Hourly	_____
Mueller Tap Machine 4" - 12"	_____	Hourly	_____
4" Cut-Off Grinder	_____	Hourly	_____
Acetylene Torch Outfit	_____	Hourly	_____
Hilti Drill	_____	Hourly	_____
Rigid Pipe Threader (with cutters)	_____	Hourly	_____
Impact Gun	_____	Hourly	_____
Air Ventilator with Hose	_____	Daily	_____
Pump (1-5 MGD)	_____	Hourly	_____
Trench Shoring (10.1 ft.-16 ft. depth)	_____	Hourly	_____
Trench Shoring (16.1 ft.-23 ft. depth)	_____	Hourly	_____

Supplemental Labor

<u>Labor Type</u>	<u>Rate Type</u>	<u>Rate</u>
Licensed Plumber	Hourly	_____
Welder w/Certificate	Hourly	_____
Electrician	Hourly	_____



LIST SUBCONTRACTORS BELOW:

---

---

---

---

---

FIRM: \_\_\_\_\_

\_\_\_\_\_  
CORPORATION/PARTNERSHIP/INDIVIDUAL

PER: \_\_\_\_\_

\_\_\_\_\_  
NAME (Typed or Printed)

TITLE: \_\_\_\_\_

ADDRESS: \_\_\_\_\_

\_\_\_\_\_  
ZIP

FED. ID NUMBER: \_\_\_\_\_

PHONE NUMBER: \_\_\_\_\_

FAX NUMBER: \_\_\_\_\_

EMAIL: \_\_\_\_\_

## SPECIAL PROVISIONS

### Work At or Near Known or Suspected Contaminated Sites

The City of Wilmington has an industrial history dating back to the mid 1600's. As a result, there are many sites within the City that have known or potential contamination located in either the soil and/or the groundwater. Some of these contaminated properties are known, others are yet to be discovered. Therefore, contractors responding to this request for proposal ("RFP") which involves intrusive ground work in various undetermined locations throughout the City must be prepared to properly deal with the site contamination issues. The contractor should be aware that often if soil or water is contaminated, it must be managed in a manner different from normal protocols. In addition, often if hazardous soil or water is disturbed, it must be disposed of off site. The contractor must also make every effort to ensure that there is no exacerbation of contamination when performing work at a contaminated site. Accordingly, the contractor must provide details on two items in its response to the RFP: (1) demonstrate that the contractor is certified by the Delaware Department of Natural Resources and Environmental Control ("DNREC") pursuant to the requirements of Delaware's Hazardous Substance Cleanup Act ("HSCA") as a "Certified HSCA Consultant" for work at or near contaminated sites or provide proof of a contract with Certified HSCA Consultant who will provide oversight for the contractor at or near contaminated sites; and (2) provide an estimate to prepare a Site Safety, Health, and Emergency Response Plan ("SSHERP") for performing intrusive ground work at or near contaminated sites.

Environmental Consultant. The Certified HSCA Consultant selected by the contractor must be certified by DNREC pursuant to the requirements of HSCA, 7 Del. Code, Chapter 91. (DNREC's website contains the current list of HSCA Certified Consultants.) The HSCA Certified Consultant shall assist with the environmental aspect of the work to be performed including discussions with DNREC, management of worker exposure issues, proper management and disposal of soil and water discharged from the dewatering activities and safety oversight. The HSCA Certified Consultant selected must demonstrate the capacity to provide oversight of intrusive work on a contaminated site 24 hours a day, seven days a week in the event of an emergency repair. The HSCA Certified Consultant will be responsible for all state, federal and local reporting requirements, which may be triggered when working at a contaminated site.

If and when a HSCA Certified Consultant is needed during the course of this contract, this item/payment will be discussed by the Contractor and The City of Wilmington as to how the cost will be handled.

Site Safety, Health and Emergency Response Plan (SSHERP). It is the responsibility of the contractor to develop and implement a SSHERP to assure that all federal, state and local statutes and regulations are complied with when performing work at a contaminated site and that the health and safety of employees are protected. The SSHERP must also include an excavation of materials handling plan. The City will make available its own SSHERP in draft-final format, which the selected HSCA Certified Consultant may choose to review and adopt. However, the City makes no representations as to the completeness or sufficiency of this plan and the document is supplied only for informational purposes. No fieldwork shall begin until the SSHERP has been submitted to DNREC and the City engineer or his/her designated representative for review.

### **Tree Protections.**

Extreme caution shall be exercised so as not to damage existing trees, shrubbery, buildings, and fixtures in the immediate construction area; any damages caused directly or indirectly shall be repaired immediately at the Contractor's expense. Contractor shall restore resources within the project boundaries to a condition that will appear to be natural or match the conditions existing prior to the start of work.

- Extreme caution shall be exercised so as to not damage existing trees in the construction area, which includes protecting roots, stems, and branches. Vehicular traffic, storage of material and equipment, soil disturbance, and root cutting of roots greater than 2" in diameter is prohibited within tree drip lines, i.e. the width of a tree's canopy as measured by a circle extending perpendicularly from the outermost tips of branches to the ground.
- Contractor shall obtain a tree permit from Public Works for all necessary root pruning, tree removal and tree replacement.
- In the event that disturbance within the dripline is unavoidable during trenching/repairs, the Contractor shall inform the Public Works certified arborist (302.576.2582) immediately to determine if the tree should be treated (i.e. improve aeration of the root zones) or be removed and replaced, at the cost of the contractor.
- 2 trees shall be planted for each public tree removed and 1 tree shall be replanted for each tree removed on private property.
- The Public Works certified arborist shall evaluate construction damage/root pruning of trees and reserves the right to determine if the extent of damage significantly affects tree health and stability and requires removal and replacement.
- Tree replacements shall conform to size and species requirements deemed appropriate by the city for the space and locations in which each trees is to be planted. Replacement trees shall be in accordance with American Standard for Nursery Stock, be 2" caliper, balled and burlapped, include stakes, mulch and gator bags, be guaranteed for a minimum of 1-year from the date of acceptance by the city, and include maintenance watering of 20 gallons/tree/week during the growing season of April through October.
- All tree work shall conform to ANSI A300 arboriculture standards and an ISA certified arborist must supervise tree work.

**COMPANY LOGO**

**INVOICE**

Invoice #  
Invoice date  
PO #  
City Contract #  
Billing Period  
Job Number if needed/contractor

**JOB SITE LOCATION**  
Brief description of work

Invoices should be broken down according to>>>>

PERSONNEL

	<u>AMT</u> HRS	RATE/HR	SUB TOTAL	TOTAL
Forman:	xx	\$	\$	\$
OT				
Laborer:				
OT				
Operator				
OT				
Driver				
OT				
Etc				

**EQUIPMENT:**

Type	xx	\$	\$	\$
------	----	----	----	----

**MATERIAL:**

All material must be listed according to paid receipts that are to be provided with each invoice.

\*\*\*\* Daily reports are also to be attached to the invoice – daily reports will include all information listed above. Certified payroll is to be attached to each invoice. The invoice is actually a summary of the attached information behind the invoice.

APPENDIX "A"

TRENCH SHORING MINIMUM REQUIREMENTS

Size and Spacing of Members												
Depth of Trench	Kind of Condition of Earth	Uprights	Stringers	Cross Braces <sup>1</sup>	Width of Trenches						Maximum Spacing	
					Up to 3 Feet	3 to 6 Feet	6 to 9 Feet	9 to 12 Feet	12 to 15 Feet	Vertical Feet	Horizontal Feet	
Feet	Minimum Dimension Inches	Maximum Spacing Feet	Minimum Dimension Inches	Maximum Spacing Feet	Up to 3 Feet Inches	3 to 6 Feet Inches	6 to 9 Feet Inches	9 to 12 Feet Inches	12 to 15 Feet Inches			
5 to 10	Hard, compact	3x4 or 2x6	6		2 x 6	4 x 4	4 x 6	6 x 6	6 x 8	6 x 8	4	6
	Likely to crack	3x4 or 2x6	3	4 x 6	4	2 x 6	4 x 4	4 x 6	6 x 6	6 x 8	4	6
10 to 15	Soft, sandy, or filled	3x4 or 2x6	Close									
			Sheeting	4 x 6	4	4 x 4	4 x 6	6 x 6	6 x 8	8 x 8	4	6
	Hydrostatic pressure	3x4 or 2x6	Close									
			Sheeting	6 x 8	4	4 x 4	4 x 6	6 x 6	6 x 8	8 x 8	4	6
15 to 20	Hard	3x4 or 2x6	Close									
			Sheeting	4 x 6	4	4 x 4	4 x 6	6 x 6	6 x 8	8 x 8	4	6
	Likely to crack	3x4 or 2x6	Close									
			Sheeting	4 x 6	4	4 x 4	4 x 6	6 x 6	6 x 8	8 x 8	4	6
Soft, sandy, or filled	3x4 or 2x6	Close										
		Sheeting	4 x 6	4	4 x 4	4 x 6	6 x 6	6 x 8	8 x 8	8 x 10	4	6
Hydrostatic pressure	3x6	Close										
		Sheeting	8 x 10	4	4 x 6	6 x 6	6 x 8	8 x 8	8 x 10	8 x 10	4	6
All other conditions	3x6	Close										
		Sheeting	4 x 12	4	4 x 12	6 x 8	8 x 8	8 x 10	10 x 10	10 x 10	4	6

<sup>1</sup>Trench jacks may be used in lieu of, or in combination with, cross braces.

Shoring is not required in solid rock, or hard shale, or hard slag.

Where desirable, steel sheet piling and bracing of equal strength may be substituted for wood.

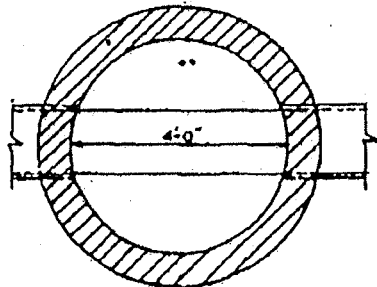
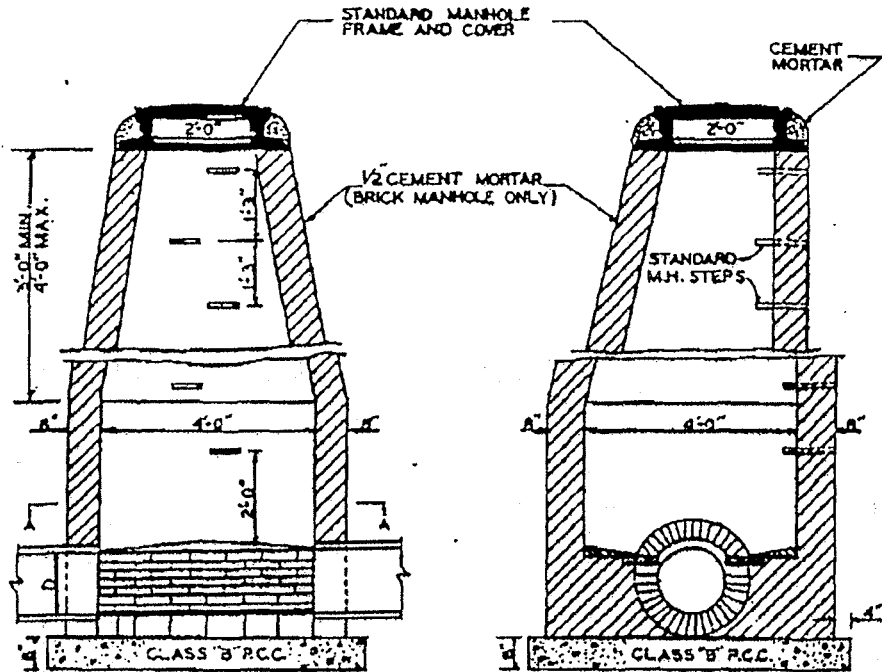

SECTION A-A

NOTE:

1. WALLS AND BOTTOM SHALL BE BRICK OR CLASS "A" CONCRETE POURED IN PLACE. INVERT SHALL BE BRICK LAID ON EDGE.
2. WHERE COVER OVER PIPE IS LESS THAN 5" USE SHALLOW MANHOLE.
3. THICKNESS OF WALLS TO BE INCREASED TO 12" 12'-0" BELOW UNDERSIDE OF FRAME.
4. IN LOW WET GROUND WALLS SHALL BE 12" THICK THROUGHOUT AS DIRECTED.
5. MAXIMUM DROP ACROSS CHANNEL SHALL BE 0.3 FOOT.

DEPARTMENT OF  
PUBLIC WORKS  
WILMINGTON, DELAWARE

STANDARD MANHOLE

DATE: 10-18-77  
REVIS: \_\_\_\_\_  
REVIS: \_\_\_\_\_  
PLATE: S-1



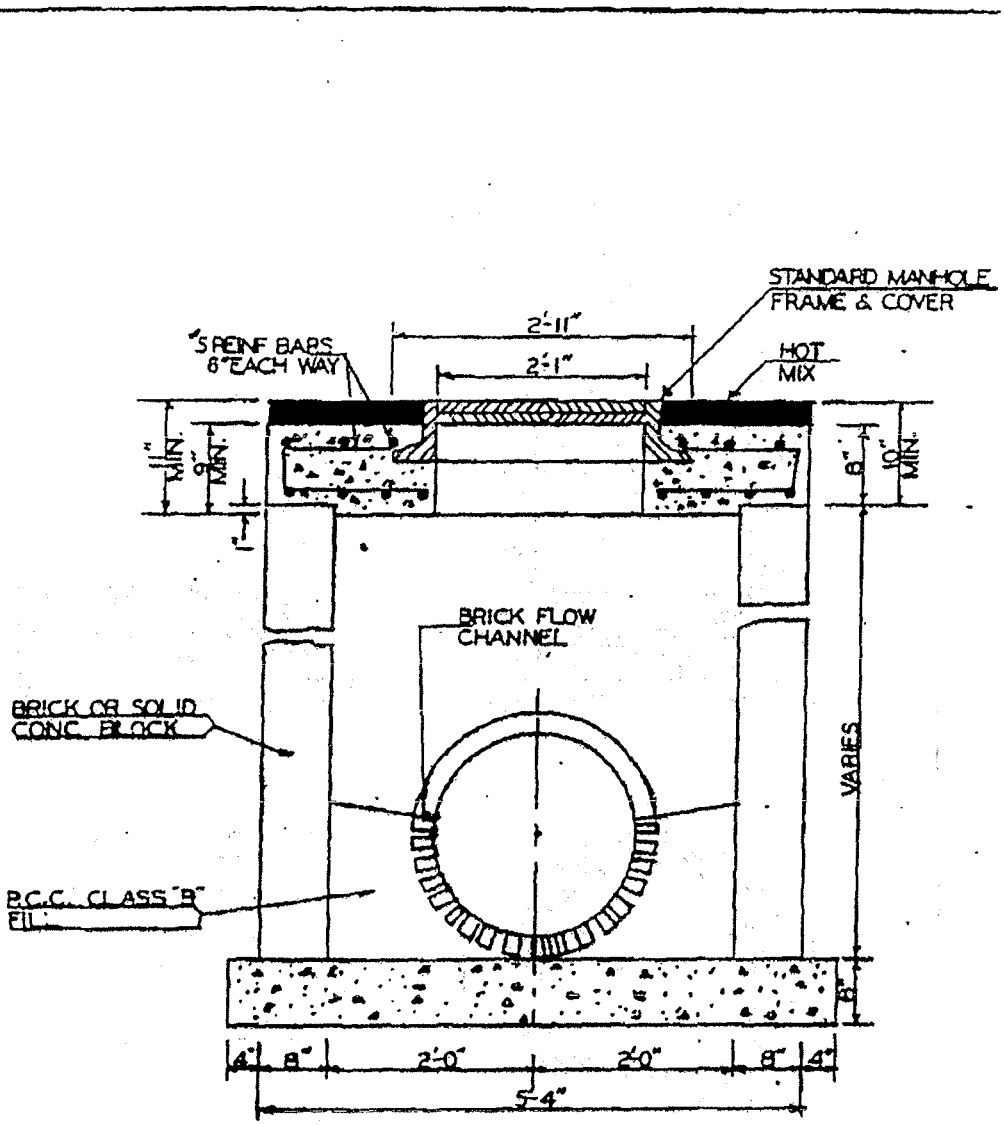

DEPARTMENT OF PUBLIC WORKS WILMINGTON, DELAWARE	MANHOLE TYPE - W SCALE: $\frac{1}{4}'' = 1'-0''$	DATE: 10-18-77 REVISION: _____ REVISION: _____ PLATE: 5-3
---	--	--

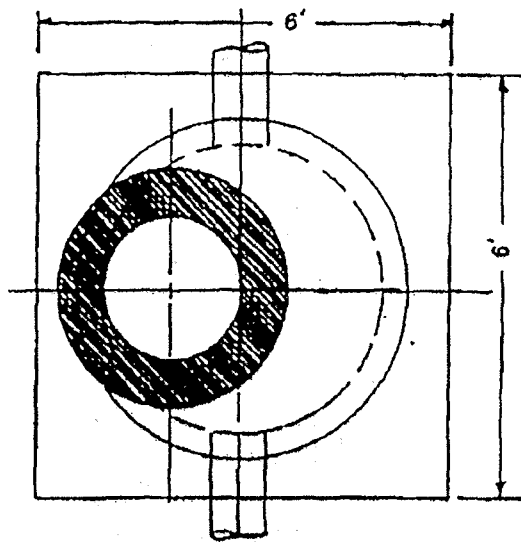

PLAN SECTION A-A B-B

FOR CONCRETE ROAD  
CONCRETE EVEN WITH  
ROAD LEVEL

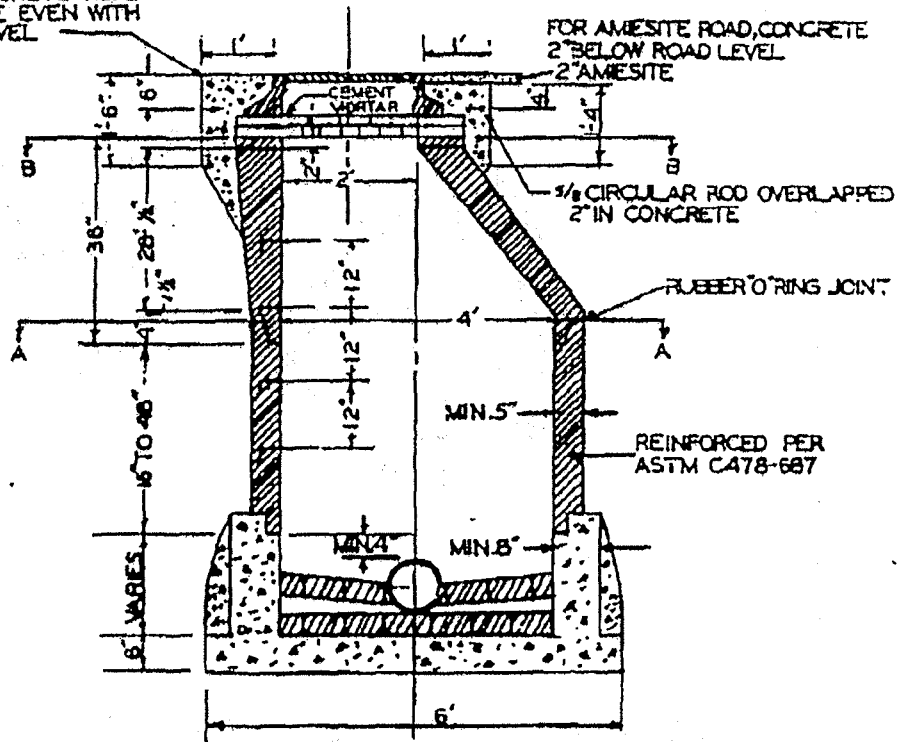

FOR AMESITE ROAD, CONCRETE  
2" BELOW ROAD LEVEL  
2" AMESITE

3/8" CIRCULAR ROD OVERLAPPED  
2" IN CONCRETE

RUBBER O-RING JOINT

MIN. 5"

REINFORCED PER  
ASTM C478-667

MIN. 8"

DEPARTMENT OF  
PUBLIC WORKS  
WILMINGTON, DELAWARE

48" PRECAST REINFORCED  
CONCRETE MANHOLE  
SCALE: 3/8" = 1'-0"

DATE: 10-18-77  
REV: - - - - -  
REV: - - - - -  
PLATE: 5-2

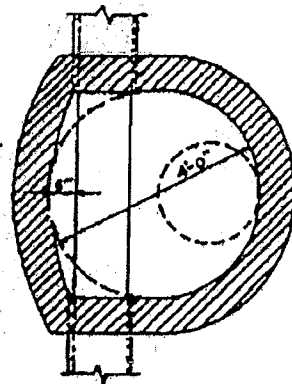
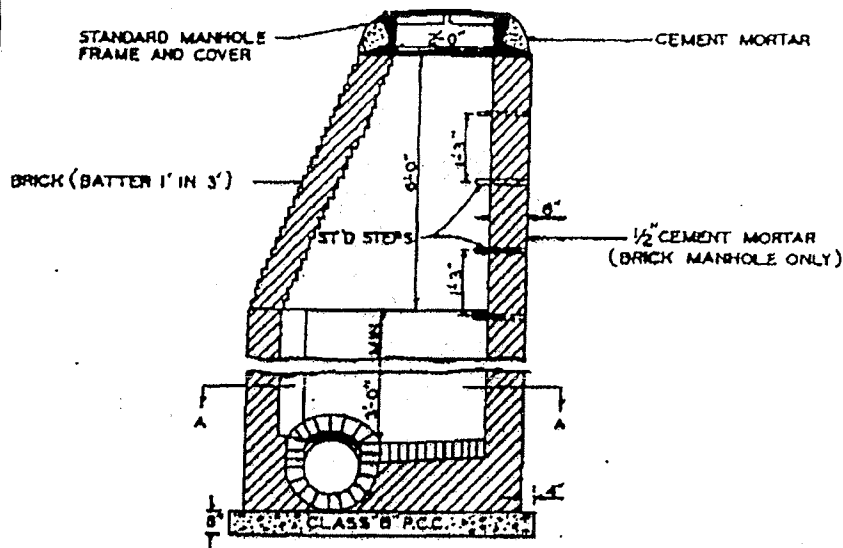

SECTION A-A

NOTES

1. WALLS AND BOTTOM SHALL BE BRICK OR CLASS "A" CONCRETE POURED IN PLACE. INVERT SHALL BE BRICK LAID ON EDGE.
2. WHERE COVER OVER PIPE IS LESS THAN 5' USE SHALLOW MANHOLE.
3. THICKNESS OF WALLS TO BE INCREASED TO 12" 12'-0" BELOW UNDERSIDE OF FRAME.
4. IN LOW WET GROUND WALLS SHALL BE 12" THICK THROUGHOUT AS DIRECTED.
5. MAXIMUM DROP ACROSS CHANNEL SHALL BE 0.3 FOOT.

DEPARTMENT OF  
PUBLIC WORKS  
WILMINGTON, DELAWARE

OFFSET MANHOLE  
WITH BATTERED BRICK

DATE: 10-18-77  
REVS: ---  
REVS: ---  
PLATE: 5-6

WILMINGTON STANDARD MANHOLE FRAME & COVER

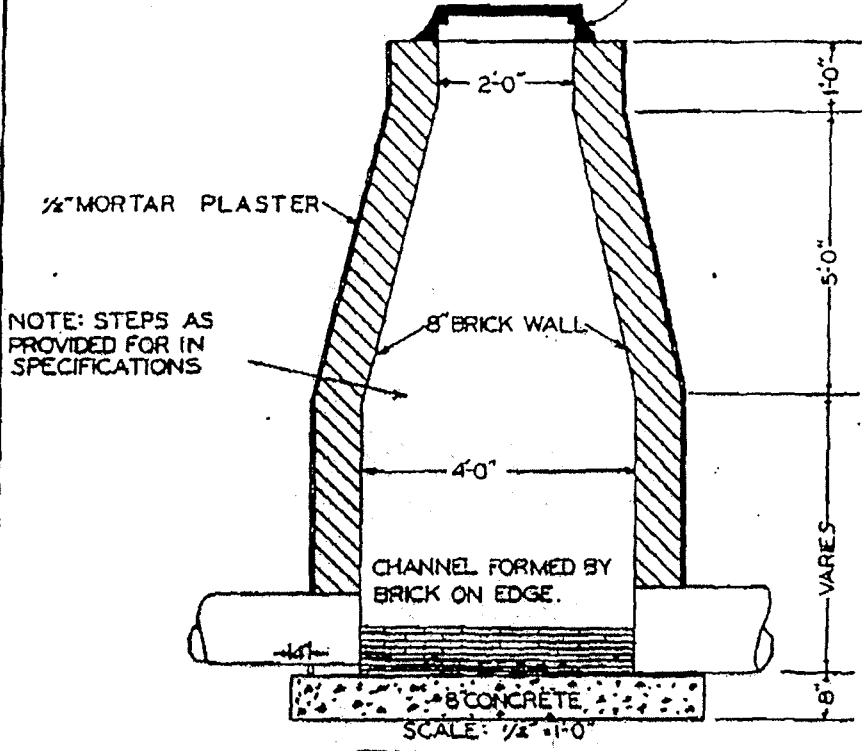

NOTE: STEPS AS PROVIDED FOR IN SPECIFICATIONS

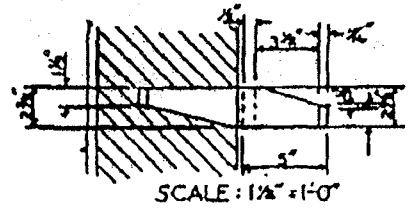
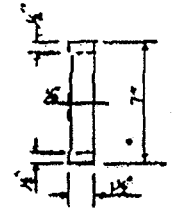
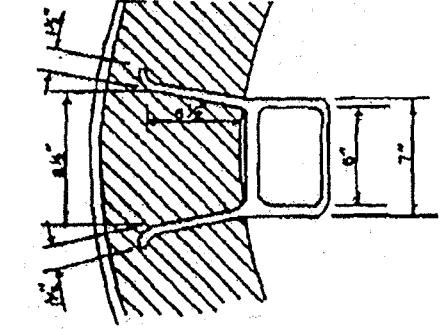

DEPARTMENT OF PUBLIC WORKS WILMINGTON, DELAWARE	STANDARD MANHOLE SECTION & STEP	DATE: 10-18-77 REVS: ..... REVS: ..... PLATE: S-7
---	------------------------------------	--

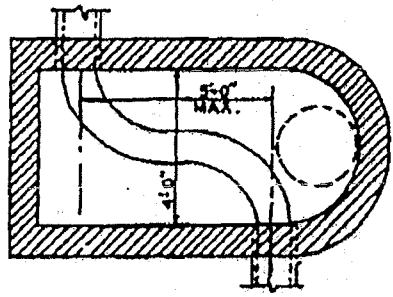
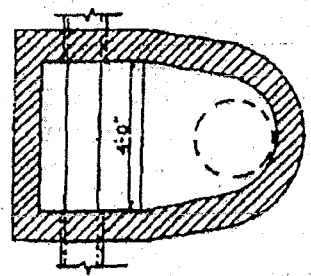
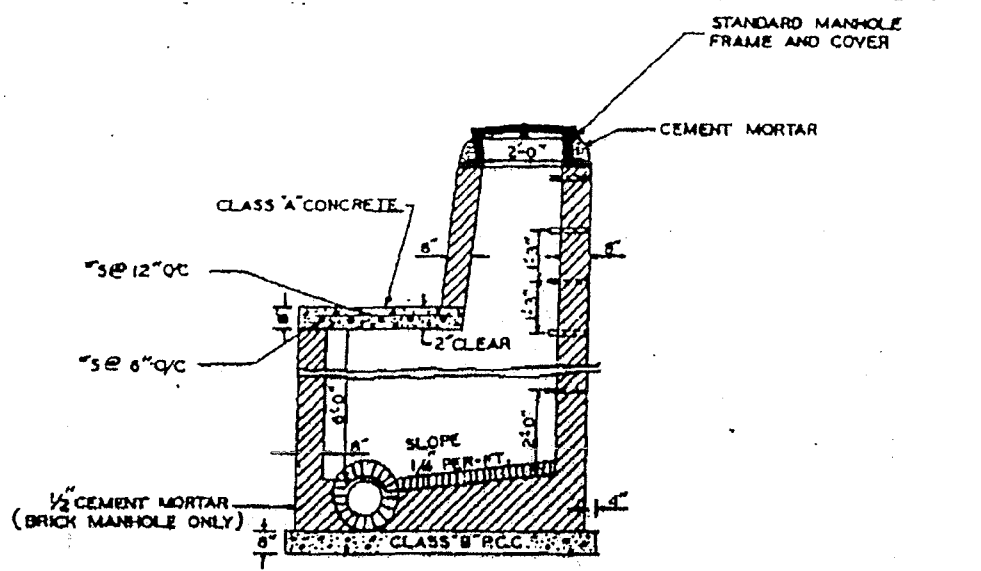

- NOTES
1. WALLS AND BOTTOM SHALL BE BRICK OR CLASS 'A' CONCRETE POURED IN PLACE. INVERT SHALL BE BRICK LAID ON EDGE.
  2. WHERE COVER OVER PIPE IS LESS THAN 5' USE SHALLOW MANHOLE
  3. THICKNESS OF WALLS TO BE INCREASED TO 12" 12'-0" BELOW UNDERSIDE OF FRAME.
  4. IN LOW WET GROUND, WALLS SHALL BE 12" THICK THROUGHOUT AS DIRECTED
  5. MAXIMUM DROP ACROSS CHANNE SHALL BE 0.3 FOOT.

DEPARTMENT OF PUBLIC WORKS	OFFSET MANHOLE WITH CONCRETE SLAB	DATE: 10-18-77 REVIS: ----- REVIS: ----- PLATE: 5-8
-------------------------------	--------------------------------------	--

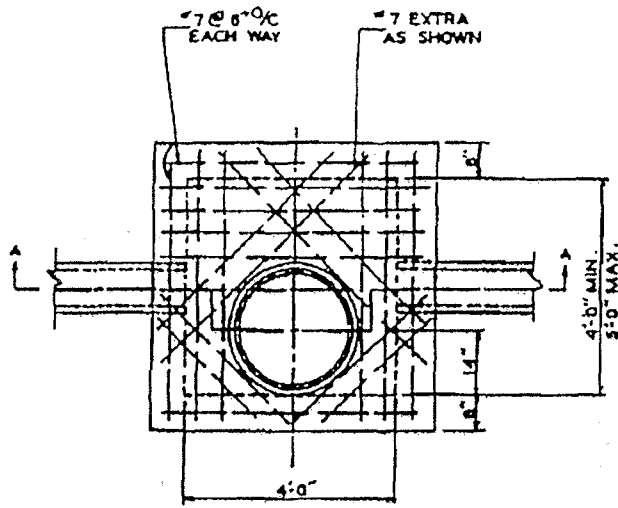

PLAN

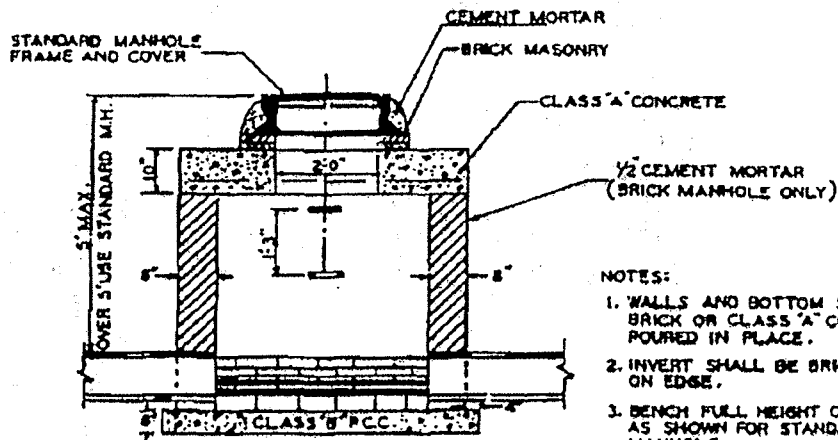

- NOTES:
1. WALLS AND BOTTOM SHALL BE BRICK OR CLASS 'A' CONCRETE POURED IN PLACE.
  2. INVERT SHALL BE BRICK LAID ON EDGE.
  3. BENCH FULL HEIGHT OF PIPE AS SHOWN FOR STANDARD MANHOLE.

SECTION A-A

DEPARTMENT OF PUBLIC WORKS WILMINGTON, DELAWARE	SHALLOW MANHOLE	DATE: 10-18-77 REVS: _____ REVIS: _____ PLATE: S-9
---	-----------------	---

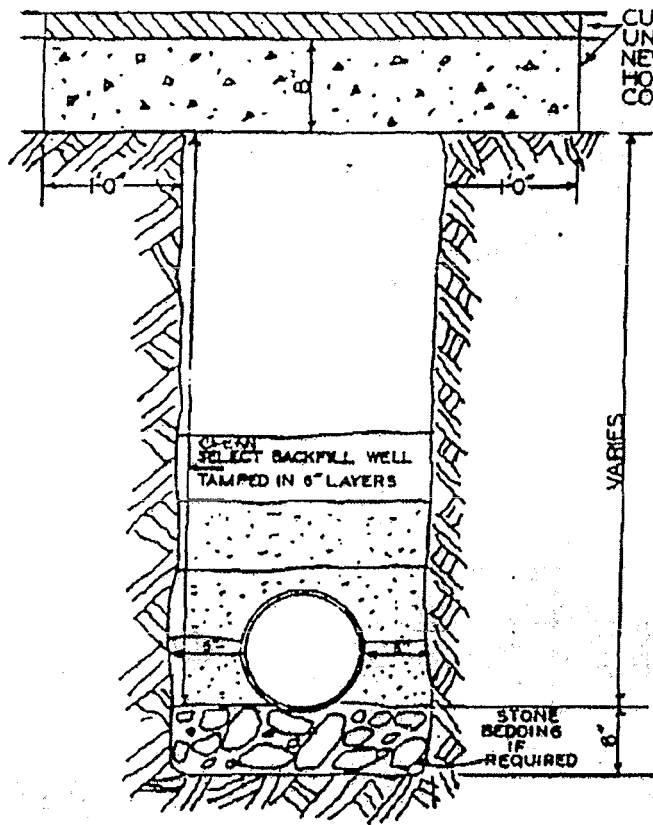

CUT EXISTING PAVING BACK 1'-0" OF UNDISTURBED GROUND AND PLACE NEW 8" CONCRETE BASE AND 2" HOT MIX HOT LAID ASPHALTIC CONCRETE.

CLEAN SELECT BACKFILL WELL TAMPED IN 6" LAYERS

VARIES

STONE BEDDING IF REQUIRED

PIPE DIAMETER	TRENCH WIDTH
6"	36"
8"	36"
10"	36"
12"	36"
15" INCLUDES 16"	36"
18"	42"
21" INCLUDES 20"	42"
24"	48"
27"	60"
30"	60"
33"	66"
36"	66"
42"	78"
48"	84"
54"	96"
60"	102"
66"	108"
72"	120"
78"	132"
84"	138"
90"	144"
102"	156"
108"	168"

DEPARTMENT OF  
PUBLIC WORKS  
WILMINGTON, DELAWARE

TRENCH AND PAVING  
REPAIR DETAIL  
SCALE: 1" = 1'-0"

DATE: 10-18-77  
REVIS: ---  
REVIS: ---  
PLATE: 5-13

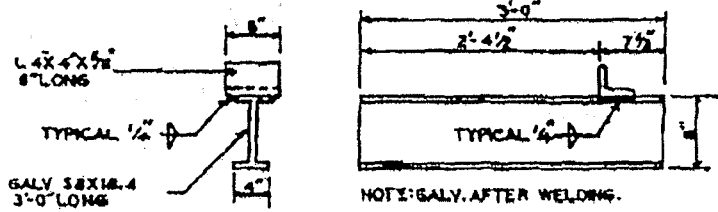
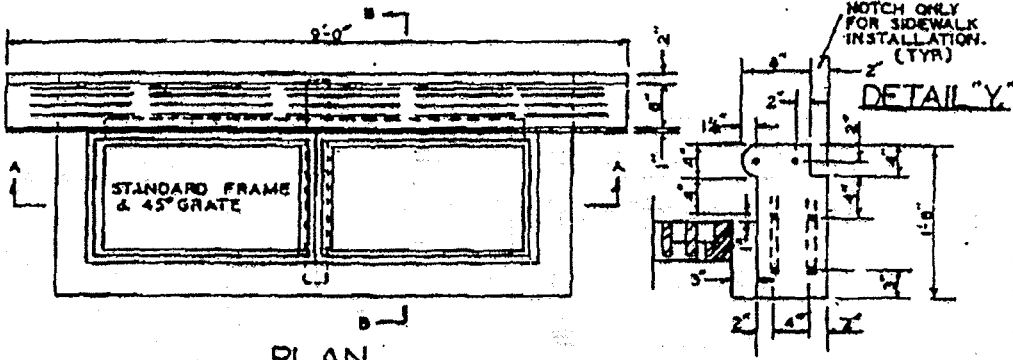
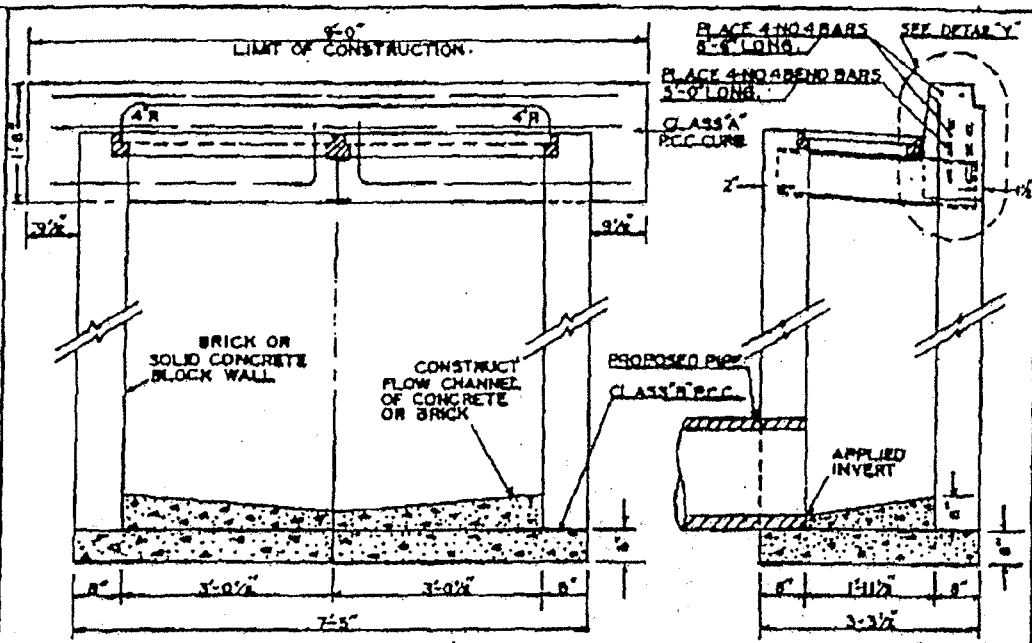

DEPARTMENT OF PUBLIC WORKS WILMINGTON, DELAWARE	TYPE I DOUBLE CATCH BASIN SCALE: 1/2" = 1'-0"	DATE: 10-18-77 REVS: _____ REVS: _____ PLATE: C-1
---	---	--



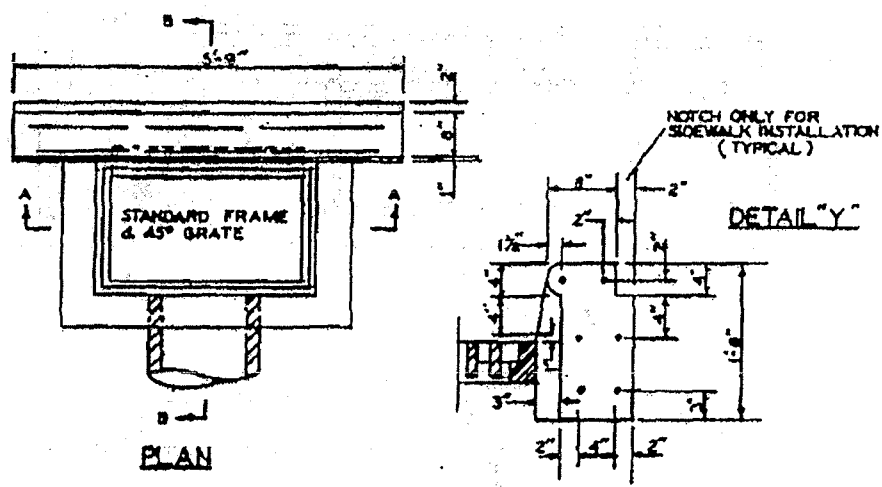
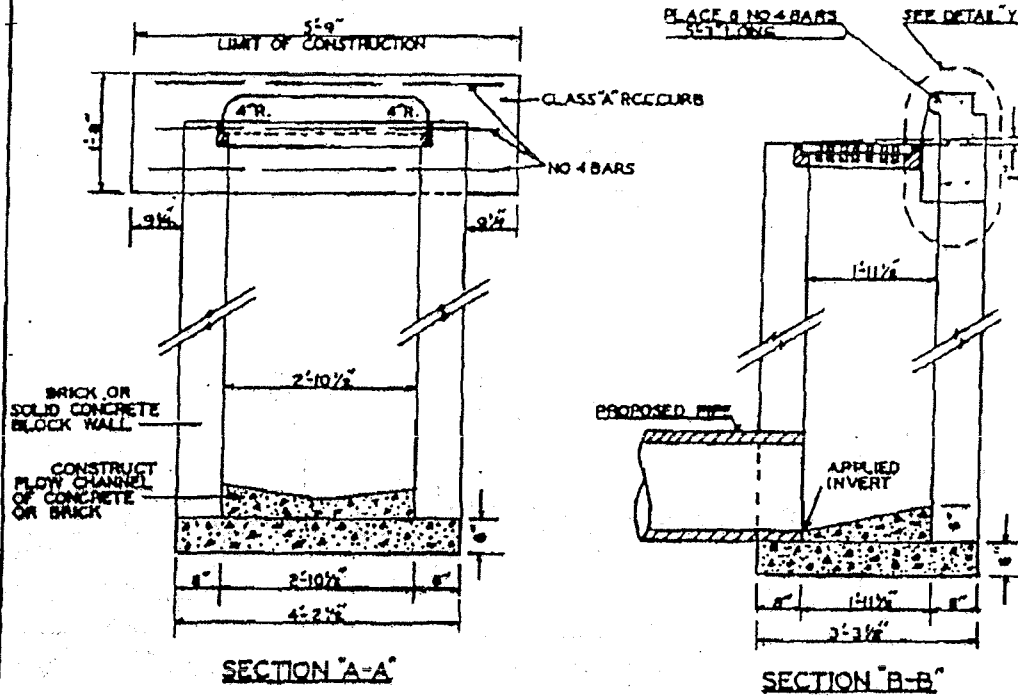

DEPARTMENT OF PUBLIC WORKS WILMINGTON, DELAWARE	TYPE "I" SINGLE CATCH BASIN SCALE: 1/2" = 1'-0"	DATE: 10-18-77 REVS: _____ REVS: _____ PLATE: C-2
---	---	--

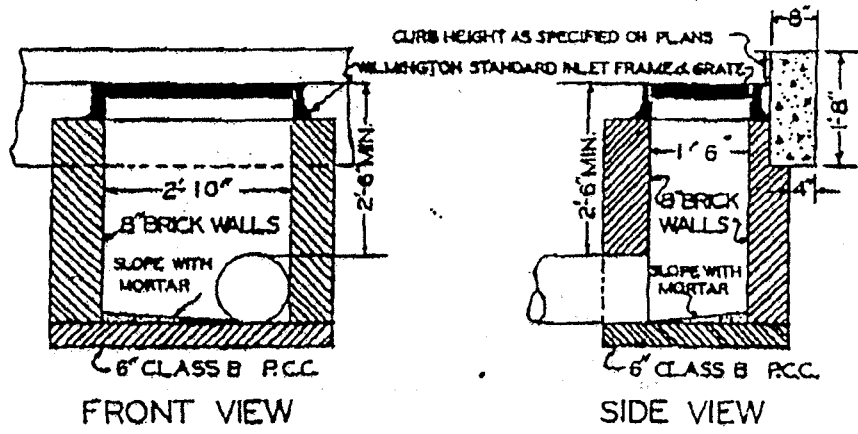

DEPARTMENT OF  
 PUBLIC WORKS  
 WILMINGTON, DELAWARE

TYPICAL TYPE "A" INLET  
 SCALE: 1/2" = 1'-0"

DATE: 10-18-77  
 REVS: 12-1-77  
 REVS:  
 PLATE: C-3

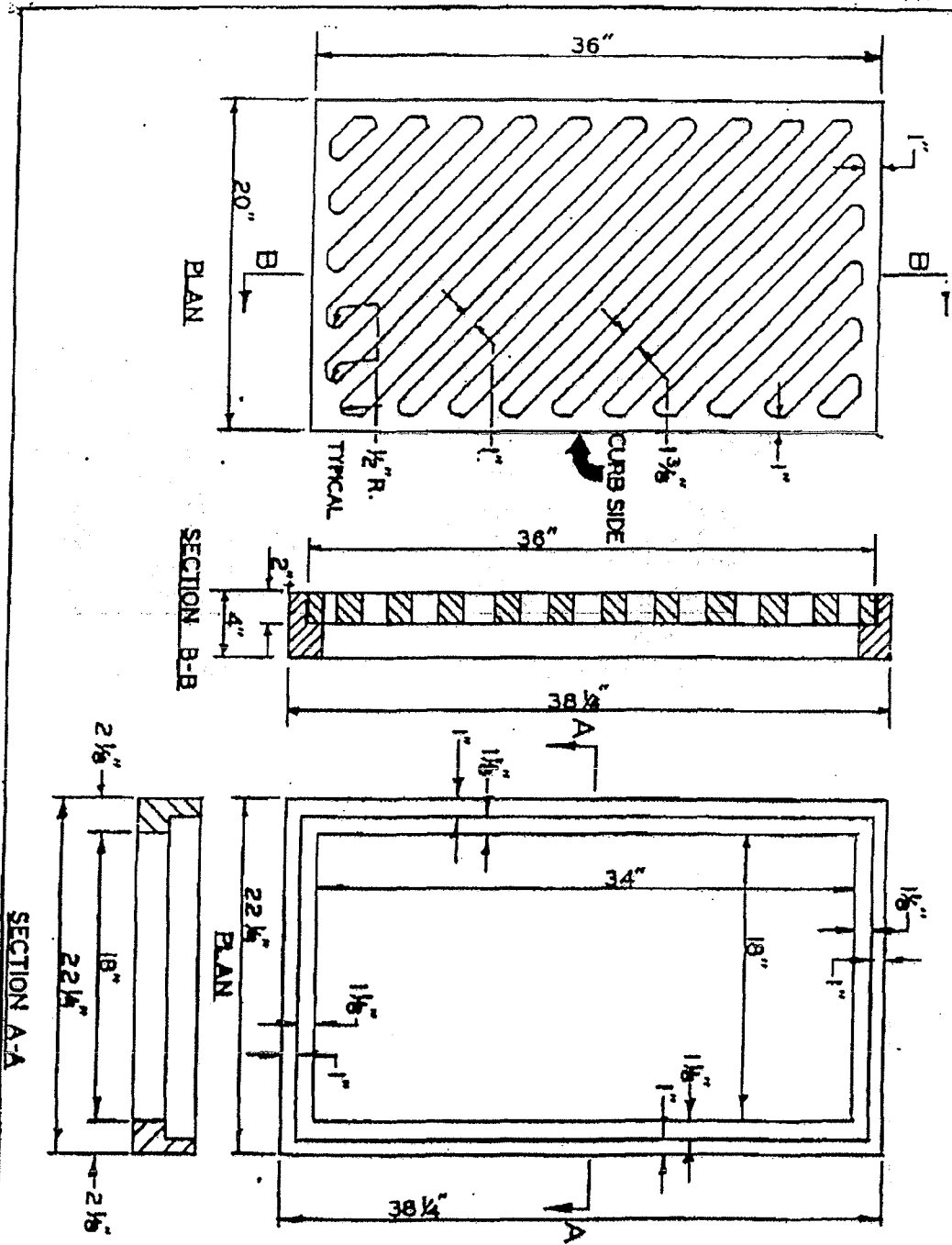

DEPARTMENT OF PUBLIC WORKS WILMINGTON, DELAWARE	STANDARD CATCH BASIN FRAME & 45° GRATE SCALE: 1 1/2" = 1'-0"	DATE: 10-18-77 REVIS: ----- REVS: ----- PLATE: C-4
---	--	---

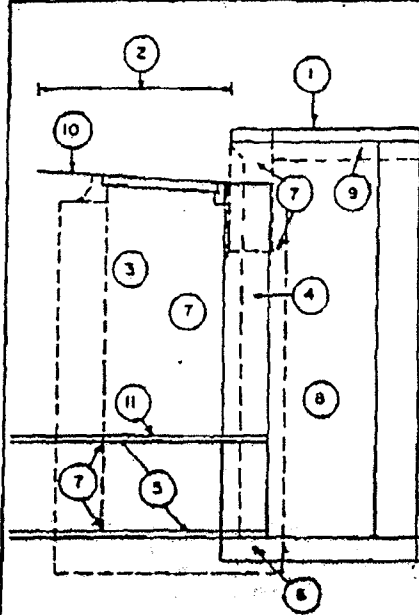

- ① REMOVE EXISTING METAL PLATE AND RETURN TO THE CITY.
- ② REMOVE PORTION OF EXISTING PAVING AS DIRECTED BY THE ENGINEER.
- ③ EXCAVATE FOR CONSTRUCTION (4± CUBIC YARDS).
- ④ REMOVE EXISTING FRONT WALL AND REQUIRED PORTIONS OF SIDE WALLS.
- ⑤ REMOVE PORTIONS OF EXISTING PIPE.
- ⑥ REMOVE PORTIONS OF EXISTING BASE.
- ⑦ CONSTRUCT NEW INLET AND CURB, CONNECT PIPE(S) TO NEW TYPE INLET AS DIRECTED BY THE ENGINEER OR PLAN.
- ⑧ PLACE COMPACTED SELECT BETWEEN BACK WALL OF NEW INLET AND REMAINS OF OLD INLET (3± CUBIC YARDS).
- ⑨ CONSTRUCT 4" CONCRETE SIDEWALK AS REQUIRED, MECHANICAL SAW EXISTING WALK FOR NEW JOINT.
- ⑩ BACKFILL AND PATCH PAVING AROUND NEW INLET.
- ⑪ PROVIDE & INSTALL 6'L.F. OF 10" E.S.V.C.P. & 2'-10" E.S.V.C. V8 BENCHES TO CONNECT TO NEW INLET.

**DETAIL "A"**

**NOTES**

1. THE ILLUSTRATED CONSTRUCTION PROCEDURE SHALL BE FOLLOWED WHERE EXISTING TYPE "A" OR TYPE "Q" INLETS ARE REPLACED WITH STANDARD INLETS.
2. ALL MATERIALS AND WORKMANSHIP SHALL BE IN ACCORDANCE WITH THE CITY OF WILMINGTON STANDARD SPECIFICATIONS.
3. SEE PLAN FOR TYPE INLET.

DEPARTMENT OF PUBLIC WORKS WILMINGTON, DELAWARE.	CONSTRUCTION PROCEDURE FOR REPLACEMENT OF EXISTING INLETS	DATE: 10-18-77
		REVIS: _____
		REVIS: _____
		PLATE: C-5

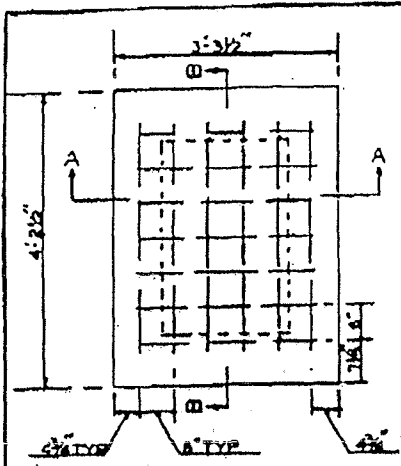

PLAN

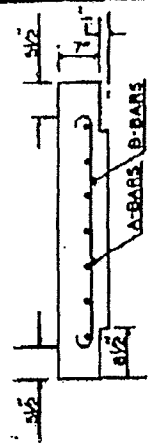

SECTION B-B

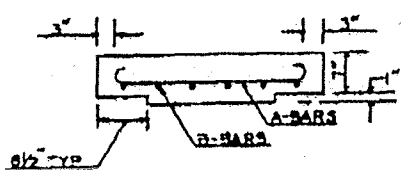

SECTION "A-A"

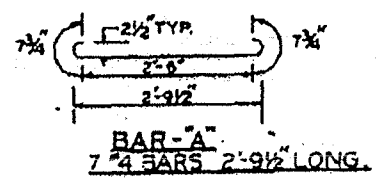

BAR-A  
7 #4 BARS 2'-9 1/2" LONG.

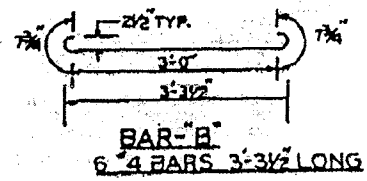

BAR-B  
6 #4 BARS 3'-3 1/2" LONG.

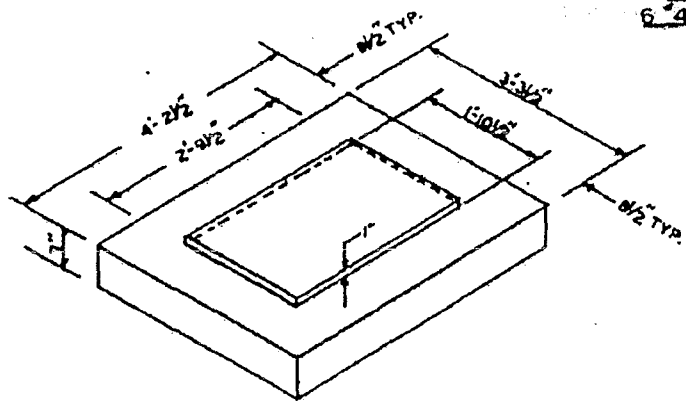

ISOMETRIC VIEW  
BOTTOM SIDE UP

NOTE: FOR CONVERSION TO  
JUNCTION BOX.

DEPARTMENT OF PUBLIC WORKS WILMINGTON, DELAWARE	REINF CONCRETE COVER FOR TYPE 1 (SINGLE C.B.) SCALE: 1/2" = 1'-0"	DATE: 10-18-77
		REVIS: -----
		REVIS: -----
		PLATE: C-6

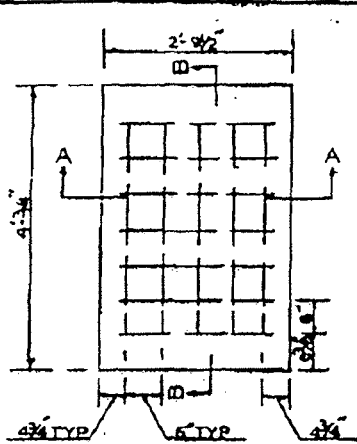

PLAN

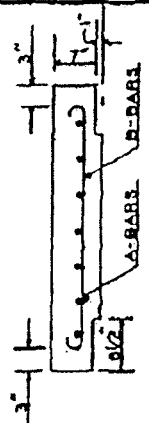

SECTION "B-B"

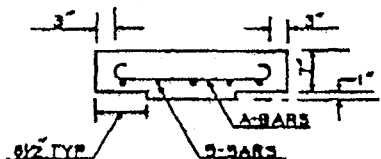

SECTION "A-A"

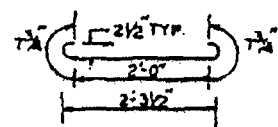

BAR "A"  
7/8" BARS 2'-3 1/2" LONG

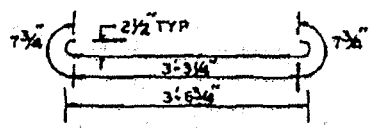

BAR "B"  
5/8" BARS 3'-6 3/4" LONG

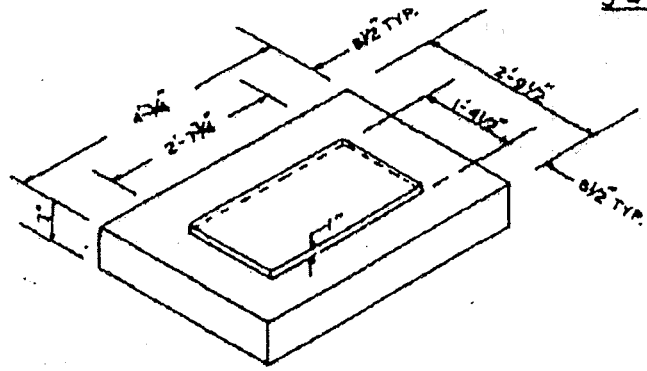

ISOMETRIC VIEW  
BOTTOM SIDE UP

NOTE: FOR CONVERSION TO  
JUNCTION BOX.

DEPARTMENT OF  
PUBLIC WORKS  
WILMINGTON, DELAWARE

REINF CONCRETE COVER  
FOR TYPE A (SINGLE C.B.)  
SCALE: 1/2" = 1'-0"

DATE: 10-18-77  
REVIS: \_\_\_\_\_  
REVIS: \_\_\_\_\_  
PLATE: C-7

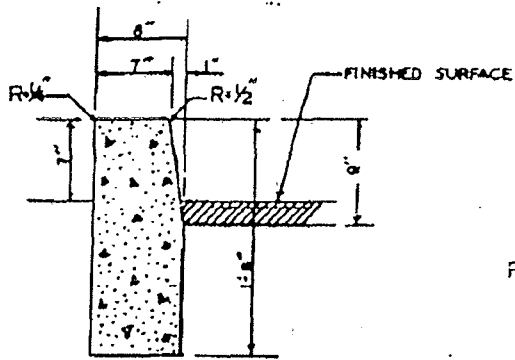

TYPE "A"

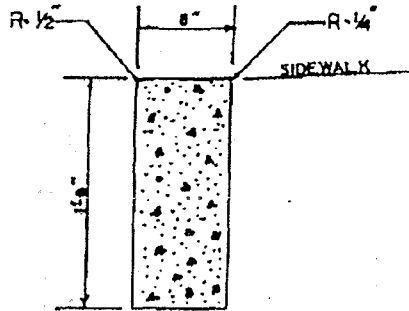

TYPE "1"

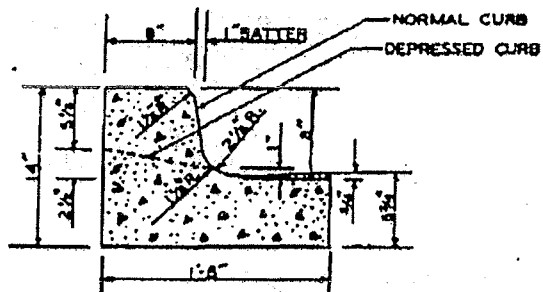

INTERGRAL R.C.C. CURB & GUTTER  
TYPE "3"

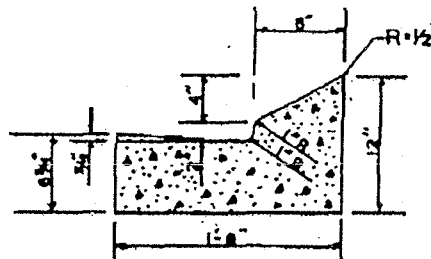

R.C.C. PARKWAY CURB  
TYPE "3"

DEPARTMENT OF  
PUBLIC WORKS  
WILMINGTON, DELAWARE

STANDARD CURB DETAILS  
SCALE: 1" = 1'-0"

DATE: 10-18-77  
REVS: \_\_\_\_\_  
REVS: \_\_\_\_\_  
PLATE: P-1

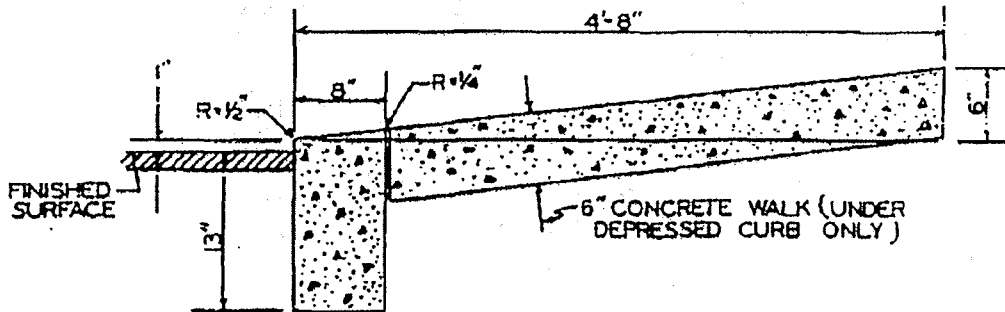
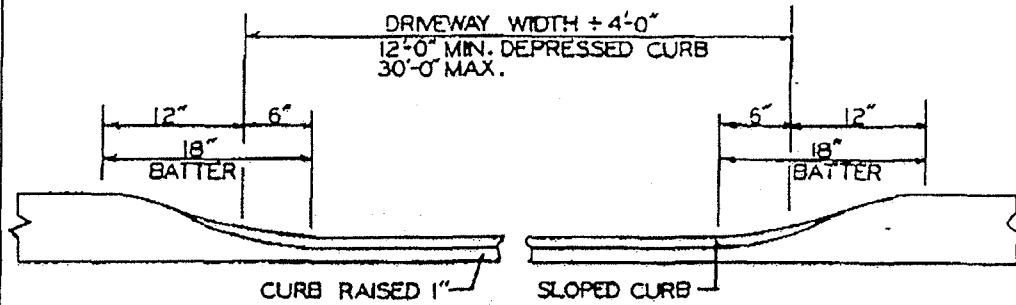

DEPARTMENT OF  
 PUBLIC WORKS  
 WILMINGTON, DELAWARE

DRIVEWAY APPROACH (TYP)  
 & DEPRESSED CURB (TYP)

DATE: 10-18-75  
 REVISION: \_\_\_\_\_  
 REVISION: \_\_\_\_\_  
 PLATE: P-2



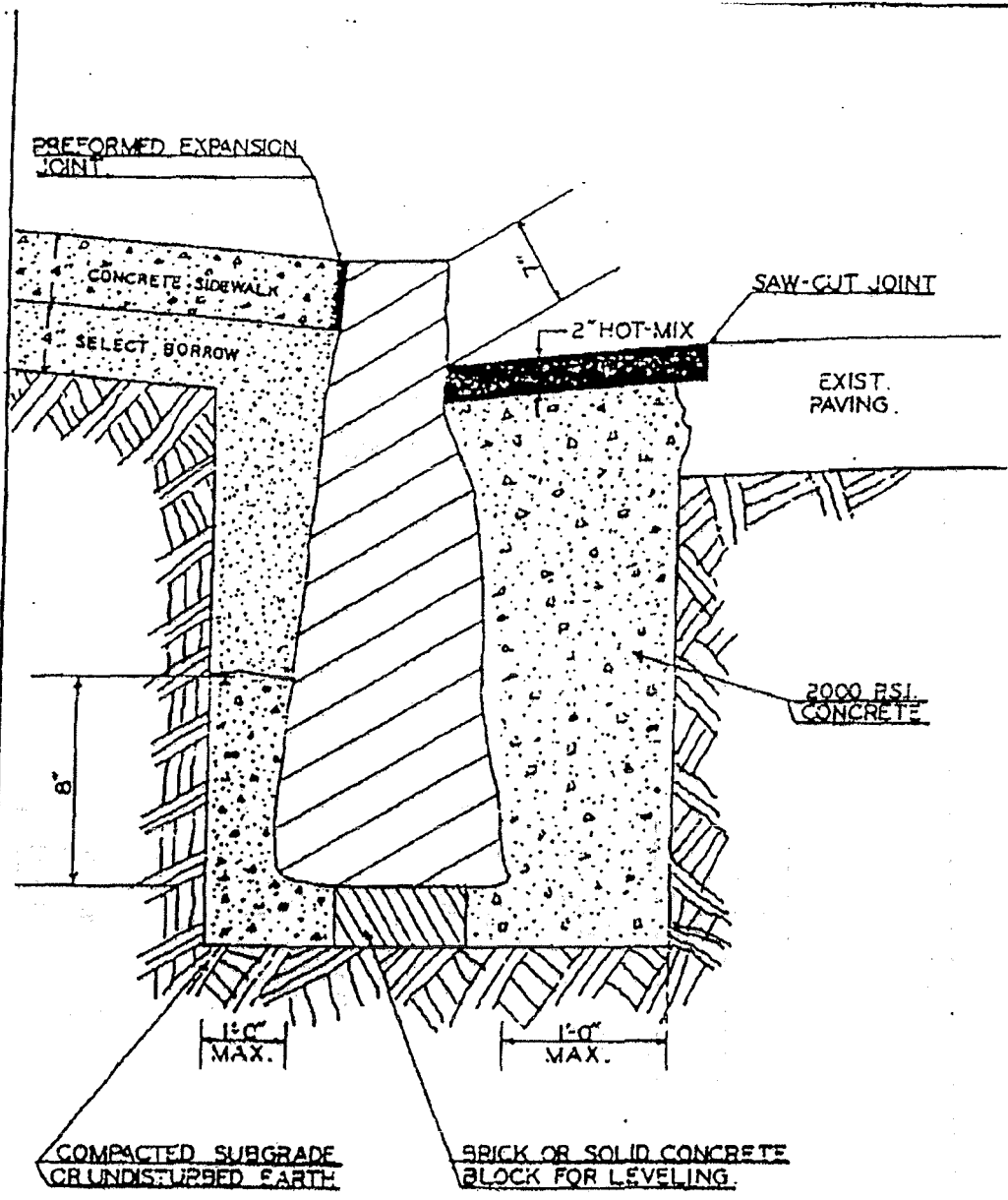

DEPARTMENT OF  
PUBLIC WORKS  
WILMINGTON, DELAWARE

RESET GRANITE CURB  
NO SCALE

DATE: 02-19-77  
REVIS: \_\_\_\_\_  
REVIS: \_\_\_\_\_  
PLATE: P-3

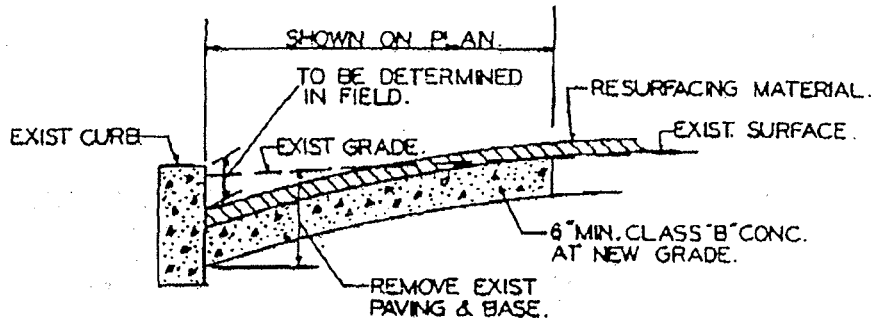

**TYPICAL GRADE ADJUSTMENT PATCH.**  
NOT TO SCALE

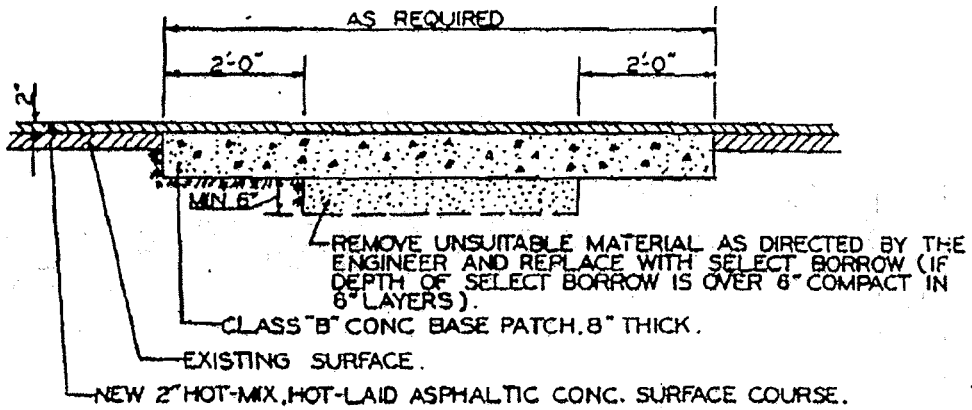

**TYPICAL STREET PATCH**  
SCALE: 1/2" = 1'-0"

DEPARTMENT OF  
PUBLIC WORKS  
WILMINGTON, DELAWARE

STANDARD PATCH DETAILS  
SCALE: AS NOTED

DATE: 10-18-77  
REVIS: \_\_\_\_\_  
REVIS: \_\_\_\_\_  
PLATE: P-5

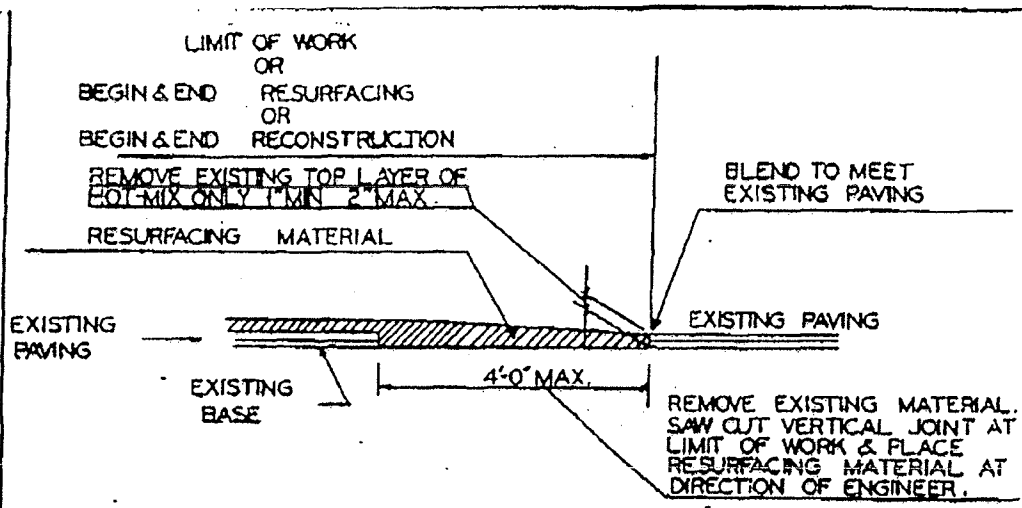

TYPICAL CUT JOINT DETAIL

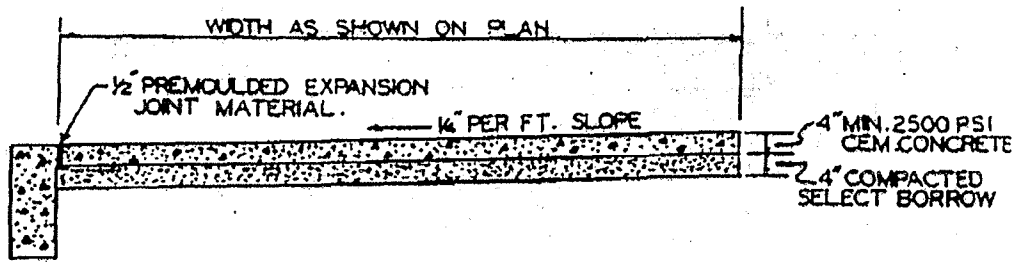

TYPICAL CEMENT CONCRETE WALK

DEPARTMENT OF PUBLIC WORKS WILMINGTON, DELAWARE	CUT JOINT DETAIL (TYP) &	DATE: JQ-18-77
	CEMENT CONCRETE WALK (TYP)	REVS: 1 - - - -
	SCALE: 1/2" = 1'-0"	REVS: 2 - - - -
		PLATE: P-6 - - -

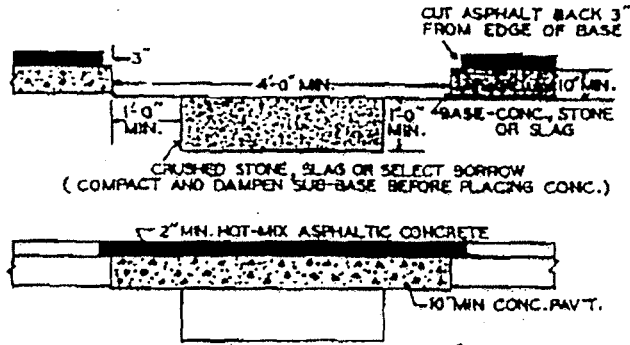

BITUMINOUS SURFACED-FLEXIBLE OR RIGID BASE

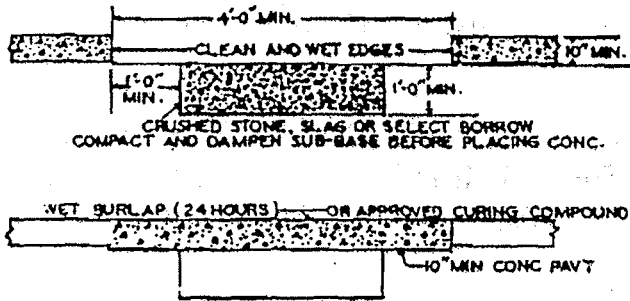

CONCRETE ROADWAY

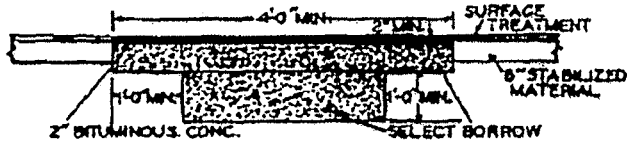

SURFACE TREATED ROADWAY

FOR STATE MAINTAINED STREETS

DEPARTMENT OF PUBLIC WORKS WILMINGTON, DELAWARE	CUTTING AND REPLACING PAVEMENTS FOR UTILITY INSTALLATIONS	DATE: 10-18-77 REVIS: _____ REVS: _____ PLATE: P-1
---	---	---

**Contractor/Subcontractor  
Responsibility Certification**

**Contractors:** The City of Wilmington Division of Procurement and Records must receive this executed form not later than at the time of bid submission. It may be submitted prior to bid submission for review.

**Subcontractors:** Must submit this form to requesting contractor.

CONTRACTOR/SUBCONTRACTOR RESPONSIBILITY CERTIFICATION  
FOR DEPARTMENT OF PUBLIC WORKS CONTRACTS  
VALUED AT MORE THAN \$100,000

Name of Company: \_\_\_\_\_

Address: \_\_\_\_\_

\_\_\_\_\_

Contract/Project Name: \_\_\_\_\_

Contract Number: \_\_\_\_\_

As a condition of performing "City work" (all building or construction work or projects of any kind or nature as provided in City Code Sec. 2-651) for the City of Wilmington, Delaware, contractors and subcontractors (hereinafter referred to as "Bidders") must meet certain responsible contractor requirements and qualifications specified in the Wilmington City Code, Chapter 2, Article VI, Division 6, Subdivision III (Sec. 2-561 et seq.). Pursuant thereto, the Company named above certifies the following:

**PLEASE INITIAL EACH ITEM TO INDICATE COMPLIANCE  
(Xs and check marks are *not* acceptable)**

\_\_\_\_\_ 1. The Bidder and its employees have all valid, effective licenses, registrations, or certificates required by federal, state, county, or local law, including, but not limited to, licenses, registrations, or certificates required to:

- a. do business in the City of Wilmington and the State of Delaware; and
- b. perform the contract work, including, but not limited to, licenses, registrations or certificates for any type of construction or maintenance trade work or specialty work which the Bidder proposes to self-perform.

\_\_\_\_\_ 2. The Bidder meets all:

- a. bonding requirements as required by the applicable law or contract specifications; and
- b. insurance requirements per applicable law or contract specifications, including general liability insurance, workers' compensation insurance, and unemployment insurance.

\_\_\_\_\_ 3. The Bidder has a satisfactory record of integrity in accordance with Sec. 2-537(4) of the City Code, which further states as follows:

The following provisions, while not exclusive, shall be sufficient to justify a finding of nonresponsibility:

- a. failure to pay taxes and fees due and owing to the City;
- b. a conviction of the contractor or a principal officer thereof for commission of a criminal offense, as incident to obtaining or attempting to obtain a public contract or in the performance of such contract;
- c. a conviction, of the contractor or principal officer thereof, under state or federal statutes, for embezzlement, theft, forgery, bribery, falsification or destruction of records, receiving stolen property, or any other offense indicating a lack of business integrity or business honesty which currently, seriously and directly affects responsibility as a city contractor.

\_\_\_\_\_ 4. The Bidder has a satisfactory record of timely performance of City contracts in accordance with Sec. 2-537(3) of the City Code, which further states as follows:

Contractors who are seriously deficient in current contract performance, when the number of contracts and the extent of deficiency of each are considered, shall, in the absence of evidence to the contrary or circumstances properly beyond the control of the contractor, be presumed to be unable to meet this requirement. Past unsatisfactory performance due to failure to apply necessary

tenacity, or perseverance to do an acceptable job, shall be sufficient to justify a finding of nonresponsibility.

\_\_\_\_\_ 5. The Bidder has a satisfactory record of performance of contractual provisions in accordance with Sec. 2-537(5) of the City Code, which further states as follows:

Violation of contract provisions of a character which justify a finding of nonresponsibility include:

- a. deliberate failure without good cause to perform in accordance with the specifications provided in the contract;
- b. a recent record of failure to perform or of unsatisfactory performance in accordance with the terms of one or more contracts;
- c. in particular, failure to comply with prevailing wage and related federal, state, and city requirements;

provided, however, that failure to perform or unsatisfactory performance caused by acts beyond the control of the contractor shall not be considered to be a basis for a finding of nonresponsibility.

\_\_\_\_\_ 6. The Bidder has a satisfactory record of good faith efforts to achieve disadvantaged business enterprise participation in accordance with Sec. 2-537(8) of the City Code.

\_\_\_\_\_ 7. The Bidder has not been debarred or suspended by any federal, state or local government agency or authority in the past three years.

\_\_\_\_\_ 8. The Bidder has not defaulted on any project in the past three years.

\_\_\_\_\_ 9. The Bidder has not had any type of business, contracting or trade license, registration, or other certification revoked or suspended in the past three years.

\_\_\_\_\_ 10. The Bidder and its owners have not been convicted of any crime relating to the contracting business in the past ten years.

\_\_\_\_\_ 11. The Bidder has not at any time been found in violation of any federal, state or local prevailing wage law.

\_\_\_\_\_ 12. The Bidder has not within the past three years been found in violation of any law applicable to its contracting business, including, but not limited to, licensing laws, tax laws, prompt payment laws, wage and hour laws, environmental laws or others, where the result of such violation was the payment

of a fine, back pay damages or any other type of penalty in the amount of \$1,000 or more.

\_\_\_\_\_ 13. The Bidder will pay all craft employees that it employs on the project the current wage rates and fringe benefits as required under applicable federal, state or local wage laws.

\_\_\_\_\_ 14. All craft labor that will be employed by the Bidder for the project have completed at least the OSHA 10 hour training course for safety established by the U. S. Department of Labor, Occupational Safety & Health Administration.

\_\_\_\_\_ 15. The Bidder will employ craft employees in all classifications and individual trades required to successfully perform the work related to the project.

\_\_\_\_\_ 16. The Bidder has participated in a Class A Apprenticeship Program for the past twelve months, at a minimum, for each separate trade or classification in which it employs craft employees and shall continue to participate in such program or programs for the duration of the project. The twelve month participation requirement may be waived during the first year of implementation of this Ordinance, provided that the firm is participating in a Class A Apprenticeship Program at the time it submits its bid and submits information showing that the construction craft workers it plans to use have adequate skills to successfully perform the project. Once the Ordinance has been in effect for twelve months, i.e., September 4, 2013, a waiver of this requirement will no longer be available.

a. for purposes of this section, a Class A Apprenticeship Program is an apprenticeship program that is currently registered with and approved by the U.S. Department of Labor or a state apprenticeship agency and has graduated apprentices to journeyman status for at least three of the past five years;

b. to ensure compliance with this section, the Bidder shall provide, with this certification, a list of all trades or classifications of craft employees it will employ on the project and documentation verifying it participates in a Class A Apprenticeship Program for each trade or classification listed;

c. in order to enhance the training of its workforce and to comply with this subsection, the firm must enroll a new person in a Class A Apprenticeship Program for each bid submitted to the City.

\_\_\_\_\_ 17. The Bidder shall make all reasonable best efforts to ensure that fifteen percent (15%) of the workforce hired for the project, especially with respect to new workers recruited and hired for the project, includes City of Wilmington residents. To ensure compliance with this section, the Bidder will also make residency information on its workforce available to the City upon request.



- \_\_\_\_\_ 18. The Bidder has all other technical qualifications and resources, including equipment, personnel and financial resources, to perform the referenced contract, or will obtain same through the use of qualified, responsible contractors.
- \_\_\_\_\_ 19. The Bidder acknowledges that within seven (7) calendar days following the date of receipt of Notice of Intent to Award Contract, it will provide a list of subcontractors it plans to utilize for services in the performance of the contract. The list must include a brief description of the subcontractor's scope of work. In addition, each subcontractor providing services equaling or exceeding \$100,000 must provide executed Subcontractor Responsibility Certifications containing information equivalent to that required for the Bidder in the Contractor Responsibility Certification. Note: Bidder must initial this item regardless of the value of the subcontract services.
- \_\_\_\_\_ 20. If at any time during the past five (5) years the Bidder has controlled or has been controlled by another corporation, partnership or other business entity operating in the construction industry, it will disclose such facts by attaching a detailed statement to its Contractor Responsibility Certification explaining the nature of the relationship.
- \_\_\_\_\_ 21. The Bidder acknowledges that it shall be required to provide appropriate documentation of the conditions specified in this Contractor/Subcontractor Responsibility Certification. The Bidder also understands that the City of Wilmington may request additional information or documents at any time as the City of Wilmington deems necessary to evaluate the responsibility of Bidder. Bidder agrees to provide such additional information or supporting documentation for this Certification.
- \_\_\_\_\_ 22. If a Bidder fails to provide the Contractor Responsibility Certification required by this section, the Bidder shall be disqualified from bidding the contract. If a Bidder fails to provide other information or documentation required by the City of Wilmington, it may be disqualified from being awarded the contract.
- \_\_\_\_\_ 23. The Bidder shall notify the City within seven days of any material changes to all matters attested to in this certification.

Under the penalty of perjury, the Bidder's authorized representative hereby certifies that all information included in the Contractor Responsibility Certification or otherwise submitted for purposes of determining the Bidder's status as a responsible contractor is true, complete and accurate and that he/she has knowledge and authority to verify the information in this certification or otherwise submitted on behalf of the Bidder by his or her signature below.

\_\_\_\_\_  
Authorized Signature

\_\_\_\_\_  
Date

\_\_\_\_\_  
Print Name

\_\_\_\_\_  
Title

\_\_\_\_\_  
Witness Signature

\_\_\_\_\_  
Date

PLEASE SUBMIT **SIGNED ORIGINAL** VERSION OF THIS FORM TO:

**CITY OF WILMINGTON  
DEPARTMENT OF FINANCE, DIVISION OF PROCUREMENT  
LOUIS REDDING CITY COUNTY BUILDING  
800 N. FRENCH STREET, 5<sup>TH</sup> FLOOR  
WILMINGTON, DE019801**

Questions regarding the this form can be sent to  
[procurement@wilmingtonde.gov](mailto:procurement@wilmingtonde.gov) or call 302.576.2423

STATE OF DELAWARE  
DEPARTMENT OF LABOR  
DIVISION OF INDUSTRIAL AFFAIRS  
OFFICE OF LABOR LAW ENFORCEMENT  
PHONE: (302) 451-3423

Mailing Address:  
225 CORPORATE BOULEVARD  
SUITE 104  
NEWARK, DE 19702

Located at:  
225 CORPORATE BOULEVARD  
SUITE 104  
NEWARK, DE 19702

PREVAILING WAGES FOR HIGHWAY CONSTRUCTION EFFECTIVE MARCH 13, 2015

CLASSIFICATION	NEW CASTLE	KENT	SUSSEX
BRICKLAYERS	49.39	49.39	14.51
CARPENTERS	42.55	51.86	41.22
CEMENT FINISHERS	31.06	30.92	19.65
ELECTRICAL LINE WORKERS	22.50	22.50	21.25
ELECTRICIANS	63.60	63.60	63.60
IRON WORKERS	42.20	23.87	25.35
LABORERS	31.10	34.12	37.75
MILLWRIGHTS	16.11	15.63	13.49
PAINTERS	48.84	48.84	48.84
PILEDRIVERS	66.42	23.75	26.95
POWER EQUIPMENT OPERATORS	39.15	32.92	29.04
SHEET METAL WORKERS	22.75	20.31	18.40
TRUCK DRIVERS	32.31	20.65	25.55

CERTIFIED: 3/13/15

BY 

ADMINISTRATOR, OFFICE OF LABOR LAW ENFORCEMENT

NOTE: THESE RATES ARE PROMULGATED AND ENFORCED PURSUANT TO THE PREVAILING WAGE REGULATIONS ADOPTED BY THE DEPARTMENT OF LABOR ON APRIL 3, 1992.

CLASSIFICATIONS OF WORKERS ARE DETERMINED BY THE DEPARTMENT OF LABOR. FOR ASSISTANCE IN CLASSIFYING WORKERS, OR FOR A COPY OF THE REGULATIONS OR CLASSIFICATIONS, PHONE (302) 451-3423.

NON-REGISTERED APPRENTICES MUST BE PAID THE MECHANIC'S RATE.

THESE RATES ARE BEING PROVIDED IN ACCORDANCE WITH DELAWARE'S FREEDOM OF INFORMATION ACT.

THEY ARE NOT INTENDED TO APPLY TO ANY SPECIFIC PROJECT.

DEPARTMENT OF PUBLIC WORKS  
WILMINGTON, DELAWARE

PROPOSAL FORM

16010PW- SEWER CONSTRUCTION

DATE: 4/21/15

Our City of Wilmington Business License is Number 001254

This Proposal is submitted with the knowledge that the Department of Finance, Procurement and Records Division, reserves the right to reject any and all proposals when in its judgment is it in the best interest of the City of Wilmington to do so.

We, the undersigned, hereby agree to furnish and deliver, per specifications, the item(s) listed below to the Department of Public Works, Wilmington, Delaware.

Section I -- The estimated items below will be used as the method of payment for the Scope of Work stated in the General Requirement section of the specifications.

<u>ITEM NO.</u>	<u>APPROXIMATE QUANTITY AND DESCRIPTION</u>	<u>UNIT PRICE</u>	<u>TOTAL PRICE</u>
Item 3	<u>EXCAVATION &amp; REMOVAL:</u> 2000 Cubic yards at <u>Twenty-Five</u> Dollars and <u>no</u> Cents per cubic yard.	<u>(\$ 25.00 )</u>	<u>\$ 50,000.00</u>
Item 4	<u>ROCK EXCAVATION:</u> 40 Cubic yards at <u>Twenty-Five</u> Dollars and <u>no</u> Cents per cubic yard.	<u>(\$ 25.00 )</u>	<u>\$ 1,000.00</u>
Item 6A	<u>SELECT BORROW:</u> 1,000 Tons at <u>Fifteen</u> Dollars and <u>no</u> Cents per ton.	<u>(\$ 15.00 )</u>	<u>\$ 15,000.00</u>

<u>ITEM NO.</u>	<u>APPROXIMATE QUANTITY AND DESCRIPTION</u>	<u>UNIT PRICE</u>	<u>TOTAL PRICE</u>
Item 6B	<u>CRUSHER RUN (CR-1):</u> 500 Tons at <u>Forty</u> Dollars and <u>no</u> Cents per ton.	(\$ <u>40.00</u> )	\$ <u>20,000.00</u>
Item 6C	<u>106A STONE:</u> 200 Tons at <u>Forty-Five</u> Dollars and <u>no</u> Cents per ton.	(\$ <u>45.00</u> )	\$ <u>9,000.00</u>
Item 6D	<u>TOPSOIL</u> 3 Tons at <u>Fifty</u> Dollars and <u>no</u> Cents per lineal feet.	(\$ <u>50.00</u> )	\$ <u>150.00</u>
Item 6E	<u>RECYCLED/CRUSHED CONCRETE:</u> 500 Tons at <u>Forty</u> Dollars and <u>no</u> Cents per lineal feet.	(\$ <u>40.00</u> )	\$ <u>20,000.00</u>
Item 9	<u>P.C.C. BASE COURSE:</u> <u>#9A</u> -Class A Portland Cement Concrete 30 Cubic Yards at <u>Two-Hundred Fifty</u> Dollars and <u>no</u> Cents per cubic yard.	(\$ <u>250.00</u> )	\$ <u>7,500.00</u>
	<u>#9B</u> -Class B Portland Cement Concrete 560 Cubic Yards at <u>Two-Hundred</u> Dollars and <u>no</u> Cents per cubic yard.	(\$ <u>200.00</u> )	\$ <u>112,000.00</u>
Item 10	<u>HOT MIX C</u> <u>10A</u> -Hot Mix 300 Tons at <u>One-Hundred Forty</u> Dollars and <u>no</u> Cents per ton.	(\$ <u>140.00</u> )	\$ <u>42,000.00</u>
	<u>10B</u> -Cold Patch 50 Tons at <u>One-Hundred</u> Dollars and <u>no</u> Cents per ton.	(\$ <u>100.00</u> )	\$ <u>5,000.00</u>

<u>ITEM NO.</u>	<u>APPROXIMATE QUANTITY AND DESCRIPTION</u>	<u>UNIT PRICE</u>	<u>TOTAL PRICE</u>
Item 15	<u>SEWER CONSTRUCTION:</u>		
	#15A-6-inch P.V.C. Pipe 600 Linear Feet at <u>Fifty</u> Dollars and <u>no</u> Cents per lineal foot.	(\$ <u>50.00</u> )	\$ <u>30,000.00</u>
	#15B-8-inch P.V.C. Pipe 300 Linear Feet at <u>Fifty</u> Dollars and <u>no</u> Cents per lineal foot.	(\$ <u>50.00</u> )	\$ <u>15,000.00</u>
	#15C-10-inch P.V.C. Pipe 300 Linear Feet at <u>Fifty</u> Dollars and <u>no</u> Cents per lineal foot.	(\$ <u>50.00</u> )	\$ <u>15,000.00</u>
	#15D-12-inch P.V.C. Pipe 200 Linear Feet at <u>Fifty</u> Dollars and <u>no</u> Cents per lineal foot.	(\$ <u>50.00</u> )	\$ <u>10,000.00</u>
	#15E-16-inch P.V.C. Pipe 100 Linear Feet at <u>Fifty</u> Dollars and <u>no</u> Cents per lineal foot.	(\$ <u>50.00</u> )	\$ <u>5,000.00</u>
	#15F-18-inch P.V.C. Pipe 100 Linear Feet at <u>Fifty</u> Dollars and <u>no</u> Cents per lineal foot.	(\$ <u>50.00</u> )	\$ <u>5,000.00</u>
Item 16	<u>STRUCTURES (REPAIR AND INSTALLATION):</u> (All castings supplied by City)		
	#16A-Brick Manhole 300 Vertical Feet at <u>Fifty</u> Dollars and <u>no</u> Cents per vertical foot.	(\$ <u>50.00</u> )	\$ <u>15,000.00</u>
	#16A2-Manholes (replace lid and frame assembly only) 20 each of <u>Fifteen-Hundred</u> Dollars and <u>no</u> Cents each.	(\$ <u>1,500.00</u> )	\$ <u>30,000.00</u>
	#16A3-Pre-cast Reinforced Concrete Manholes 200 Vertical Feet at <u>Two-Hundred</u> Dollars and <u>no</u> Cents each.	(\$ <u>200.00</u> )	\$ <u>40,000.00</u>

<u>ITEM NO.</u>	<u>APPROXIMATE QUANTITY AND DESCRIPTION</u>	<u>UNIT PRICE</u>	<u>TOTAL PRICE</u>
	#16B-Lamphole 4 Each at two-Hundred Fifty Dollars and no Cents each.	(\$ 250.00 )	\$ 1,000.00
	#16C-Install, Repair and Restore (paring catch basin walls) Catch Basin Type "A" or "I" 160 Vertical Feet at Three-Hundred Dollars and no Cents per vertical foot.	(\$ 300.00 )	\$ 48,000.00
	#16D-Install, repair, and restore (paring catch basin walls) double Catch Basin Type "A" or "I" 60 Vertical Feet at Three-Hundred Twenty-Five Dollars and no Cents per vertical foot.	(\$ 325.00 )	\$ 19,500.00
Item 19	<u>Curb 19A-PORTLAND CEMENT CURB</u>  120 Lineal Feet at Fifteen Dollars and no Cents per lineal foot.	(\$ 15.00 )	\$ 1,800.00
	<u>19B-GRANITE CURB</u>  20 Lineal Feet at Fifteen Dollars and no Cents per lineal foot.	(\$ 15.00 )	\$ 300.00
Item 20	<u>PORTLAND CEMENT CONCRETE SIDEWALK:</u>  4-inch Thick Sidewalk 800 Square Feet at Seven Dollars and no Cents per square foot.	(\$ 7.00 )	\$ 5,600.00
Item 35	<u>CUT-INS (CORE-DRILLED):</u>  #35A*-100 Cut-Ins at One-Hundred Dollars and no Cents each.	(\$ 100.00 )	\$ 10,000.00
	#35C-Mechanical Saw Cut 2,100 Lineal Feet at Four Dollars and no Cents per lineal foot.	(\$ 4.00 )	\$ 8,400.00

**Year 1 – Subtotal of All Items Listed for Section I**    \$ 541,250.00

\* The “cut-in” item (#35A) appearing on the Proposal Form, includes connecting to the main line and manholes where specified. In addition, all cut-ins must be core-drilled.



**Section II** – The items below will be used as a method of payment for work not covered by the items in Section I and for force account work. This section will be estimated for a time period of 120 days.

Bricklayer (1)	8 hour/day @	\$ 51.00	=	\$ 408.00
Working Foreman (1)	8 hour/day @	\$ 42.50	=	\$ 340.00
Laborer (1)	8 hour/day @	\$ 42.50	=	\$ 340.00
Radio Pick-Up Truck (1)	8 hour/day @	\$ 1.00	=	\$ 8.00
Pick-Up/Tool/Crew Truck (1)	8 hour/day @	\$ 10.00	=	\$ 80.00
Air Compressor w/Tools (125 CFM) (1)	4 hour/day @	\$ 2.00	=	\$ 8.00
2" – 3" Submersible Pump	4 hour/day @	\$ 1.25	=	\$ 5.00
Dump Truck (Single Axle)	8 hour/day @	\$ 20.00	=	\$ 160.00
Dump Truck (Tri Axle)	8 hour/day @	\$ 25.00	=	\$ 200.00
Trackhoe (5/8 to ¾ yard)	8 hour/day @	\$ 20.00	=	\$ 160.00
Flagger	8 hour/day @	\$ 35.00	=	\$ 280.00
Flatbed/ Stake body or Winch Truck	8 hour/day @	\$ 5.00	=	\$ 40.00
Tractor Truck w/ Lowboy Trailer	2 hour/day @	\$ 20.00	=	\$ 40.00
Tamper (Gas) (1)	2 hour/day @	\$ 1.50	=	\$ 3.00
Road Sign (1)	each per day @	\$ 1.50	=	\$ 1.50
Barrels/Barricades/Cones (1)	each per day @	\$ 1.50	=	\$ 1.50
Driver (1)	8 hour/day @	\$ 45.00	=	\$ 360.00
Equipment Operator (1)	8 hour/day @	\$ 55.00	=	\$ 440.00
Backhoe/Loader (1)	8 hour/day @	\$ 20.00	=	\$ 160.00
Trailer/Boom Truck (1)	2 hour/day @	\$ 5.00	=	\$ 10.00
Trench Shoring (5 ft.-10 ft. depth)	8 hour/day @	\$ 5.00	=	\$ 40.00
Backhoe w/Hydro Hammer	4 hour/day @	\$ 20.00	=	\$ 80.00
Steel Road Plate (1)	each per day @	\$ 10.00	=	\$ 10.00
Arrow Board (1)	8 hour/day @	\$ 5.00	=	\$ 40.00
Pipe Saw/Chain Saw (1)	2 hour/day @	\$ 1.00	=	\$ 2.00
Large Paving Saw (Walk Behind) (1)	2 hour/day @	\$ 15.00	=	\$ 30.00
Paving Roller (1)	2 hour/day @	\$ 15.00	=	\$ 30.00
Cement Finisher	8 hour/day @	\$ 35.00	=	\$ 280.00

**Subtotal of all items listed for Section II times 120 days \$ 426,840.00**

**Section III-** The items below will be used as a method of payment for work not covered by the items in Section I and Section II for force account work. This section will be estimated for a time period of 30 days.

Sewer Jet/ Vacuum Truck            4 hour/day @    \$ 250.00            =    \$ 1,000.00

**Subtotal of all Items above in Section III times 30 days =** \$ 30,000.00

**Grand Total:**

**Subtotal Section I + Subtotal Section II + Subtotal Section III =**  
\$ 998,090.00

Supplemental Equipment for Force Account Work (only) (not to be calculated with bid prices).

<u>Item</u>	<u>Proposal Substitution</u>	<u>Rate Type</u>	<u>Unit Price</u>
Welding Rig		Hourly	50.00
Water Truck		Hourly	50.00
Nu-Mo Gopher		Hourly	35.00
Air Drill		Hourly	25.00
Small Paving Hand Saw		Hourly	35.00
Generator (2,500 W)		Hourly	30.00
Tri-Pod Work Light		Hourly	30.00
Electric Sump Pump		Hourly	30.00
Rammax Compactor		Hourly	50.00
Mueller Tap Machine 3/4" - 2"		Hourly	50.00
Mueller Tap Machine 4" - 12"		Hourly	75.00
4" Cut-Off Grinder		Hourly	20.00
Acetylene Torch Outfit		Hourly	20.00
Hilti Drill		Hourly	20.00
Rigid Pipe Threader (with cutters)		Hourly	30.00
Impact Gun		Hourly	20.00
Air Ventilator with Hose		Daily	250.00
Pump (1-5 MGD)		Hourly	75.00
Trench Shoring (10.1 ft.-16 ft. depth)		Hourly	125.00
Trench Shoring (16.1 ft.-23 ft. depth)		Hourly	250.00

Supplemental Labor

<u>Labor Type</u>	<u>Rate Type</u>	<u>Rate</u>
Licensed Plumber	Hourly	150.00
Welder w/Certificate	Hourly	150.00
Electrician	Hourly	90.00



LIST SUBCONTRACTORS BELOW:

Rock Solid Contracting

---

---

---

---

---

FIRM: Brandywine Construction Co., Inc.

A Corporation  
CORPORATION/PARTNERSHIP/INDIVIDUAL

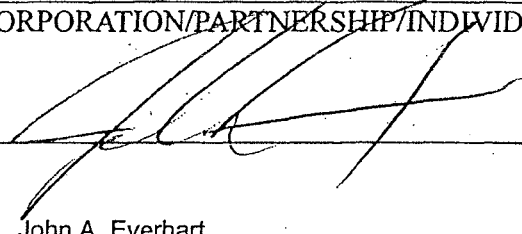
PER: 

John A. Everhart  
NAME (Typed or Printed)

TITLE: Vice President

ADDRESS: 101 Pigeon Point Road

New Castle, DE 19720  
ZIP

FED. ID NUMBER: 51-0080296

PHONE NUMBER: 302-571-9773

FAX NUMBER: 302-571-9775

EMAIL: jeverhart@bccico.com

**To Be Submitted with Bid**

CONTRACT: 16010PW

FORM DBE-1  
(Rev. 10/09)

*Failure to submit this completed form will be cause for rejection of your proposal*

Bidder acknowledges that he has read the D.B.E. goal provisions of the City for this fiscal year and that bidder will expend the dollar amount of the contract for D.B.E. subcontractors through the use of the following disadvantaged business enterprises, subject to the certification by the City, as subcontractors and that Bidder has made good faith efforts\* as evidenced by its listing of disadvantaged businesses that were contacted as detailed herein and on the following pages. (Must be completely filled out.)

**CITY OF WILMINGTON  
DISADVANTAGED BUSINESS ENTERPRISE ("D.B.E.")  
SUBCONTRACTOR LISTING**

D.B.E. Firm Name IRS Numbers	Mailing Address & Contact Number	Type of Service	Dollar Amount of Contract
Rock Solid Contracting	1213 B. Street Wilmington, DE 19801	Vac Truck	30,000.00
EIN #56-2563762	Phone: 302-655-8250	MOT	33,600.00
		Precast	20,000.00
		Curbs and Sidewalks	7,700.00
Total Dollar Amount to be Expended for Disadvantaged Business Enterprises	\$91,300.00		
Total Amount of Contract	\$998,090.00		
Percentage of Contract used for D.B.E.	9.14%		

John A. Everhart

Vice President

**Name of Authorized Official of Bidder**

**Title**

Brandywine Construction Co., Inc.

**Company**

\*Good faith efforts shall be evidenced by listing each and every disadvantaged business enterprise (DBEs) contacted, showing the name and address of each, the names of contact persons, telephone numbers, sources used to identify DBEs, methods used to make contact, dates firms were contacted, responses, dates responses were received, type of subcontract, reasons for rejection, and estimated value of subcontract.

**To Be Submitted with Bid**

CONTRACT: 16010PW

FORM DBE-2  
(Rev. 10/09)

*Failure to submit this completed form will be cause for rejection of your proposal*

DBE Firm Name/Address	Contact Person(s) Email or Phone Number	Dates Contacted Initially and In-Follow Up; Methods Used	Type of Subcontractor, plus Estimated Value	Reason for Rejection (If Firm Not Used) (If Bid "Too High" Also Indicate Value)
1.	All work that, at the time of bid, BCCI intends to subcontract	is proposed to be performed by	City DBE's (See Form DBE-1)	
			\$	
2.				
			\$	
3.				
			\$	

Were advertisements placed in general circulation media, trade association publications, and DBE media interested in DBE participation? If so, state details of the advertisement. If not, state why not.

---

What efforts were made to use the services of organizations that provide assistance in recruitment and placement of DBEs?

---

The following are examples of actions that may not be used as justification by the contractor or bidder for failure to meet DBE participation goals:

1. Failure to contract with a DBE solely because the DBE was unable to provide performance and/or payment bonds.
2. Equipment idled by contract with DBE.
3. Rejection of a DBE because of its union or non-union status.

If more DBE firms have been contacted, please list with supplemental form(s) on additional pages.

**To Be Submitted with Bid if DBE is not listed in City DBE Directory**

CONTRACT: 16010PW

FORM DBE-3  
(Rev. 10/09)

\*\*\*\*Proposed DBE's are listed in the City Directory (See Form DBE-1)

*Failure to submit this completed form will be cause for rejection of your proposal*

**CITY OF WILMINGTON  
DISADVANTAGED BUSINESS REGISTRATION VERIFICATION FORM**

1.	NAME:		
2.	ADDRESS:		
3.	PHONE:	PRODUCT OR SERVICE LINE:	
4.	TYPE OF FIRM: <input type="checkbox"/> Corporation <input type="checkbox"/> Partnership <input type="checkbox"/> Individual <input type="checkbox"/> Other _____		
5.	EMAIL:		
6.	DATE OF ORIGATION OF FIRM:	EMAIL:	
7.	BUSINESS LICENSES HELD:	City:	State:      Other:
8.	DISADVANTAGED OWNERSHIP OF FIRM:		
	NAME	OWNERSHIP % OF FIRM	DISADVANTAGED BUSINESS
a.			
b.			
c.			
d.			
e.			
f.			
9.	NON-DISADVANTAGED OWNERSHIP OF FIRM:		
	NAME	OWNERSHIP % OF FIRM	
a.			
b.			
c.			
d.			
e.			
f.			
8.	I hereby certify that the information above is true and complete to the best of my knowledge and belief, and that I have been duly authorized to make this certification on behalf of the firm.		

John A. Everhart  
NAME (printed)  
April 21st, 2015  
DATE

  
SIGNATURE  
Vice President  
TITLE

FOR OFFICE USE ONLY

DATE RECEIVED: \_\_\_\_\_  
DATE APPROVED: \_\_\_\_\_  
INFORMATION VERIFIED: \_\_\_\_\_



The General Contractor is required to submit this Compliance Report to the Disadvantaged Business Development Officer, City/County Building, 3<sup>rd</sup> Floor, 800 French Street, Wilmington, Delaware 19801, when the contract is entered into by the general contractor and the subcontractor, when 50% and when 100% of each DBE subcontractor's portion of a construction project has been completed.

**DISADVANTAGED BUSINESS ENTERPRISE  
CONTRACT PARTICIPATION REPORT**

1. Contract No. 16010PW Amount of Contract \$ 998,090.00
2. Name of General Contractor: Brandywine Construction Co., Inc.
3. Address: 101 Pigeon Point Road New Castle, DE 19720
4. E-Mail Address: jeverhart@bccico.com
5. The above-named contractor intends to fulfill its commitment to expend \$ 91,300.00 (9.14%), of its contract with Disadvantaged Business Enterprises ("DBEs"). The following year-to-date expenditure(s) has been made with a DBE Subcontractor(s):

Name/Address of DBE Subcontractor	Nature of Participation	Dollar Value/ Percent of Participation	Dollar Amount Expended to Date
1. Rock Solid Contracting 1213 B Street	Vac Truck, Precast, Sidewalks, Curbs, and MOT	91,300.00 / 9.14%	
2.			
3.			

CONTRACT COMPLETION DATE: \_\_\_\_\_

Brandywine Construction Co., Inc. John A. Everhart 4/21/15

General Contractor Name of Authorized Officer Date

Rock Solid Contracting [Signature] \_\_\_\_\_

DBE Subcontractor Signature of Authorized Officer Date

<b>Office Use Only (Prime)</b>
Payment Received: _____
Amount: _____
Date: _____
Payment Received: _____
Amount: _____
Date: _____

City of Wilmington Date

Contract Compliance Officer's Name \_\_\_\_\_

City of Wilmington Date

Contract Compliance Officer's Signature \_\_\_\_\_

CONTRACT: 16010PW

FORM DBE-5  
(Rev. 10/09)

*Failure to submit this completed form will be cause for rejection of your proposal*

**CITY OF WILMINGTON  
SUBCONTRACTOR LISTING  
(Do not include DBE Firms to be utilized)**

Subcontractor Name IRS Numbers	Mailing Address Contact Number or Email	Type of Service	Dollar Amount of Contract
Total Dollar Amount to Non-Disadvantaged Business Enterprises	None		
Total Amount of Contract	\$998,090.00		

Bidder acknowledges that he has identified all sub contractors that will be utilized as well as listing the amount of money that will be paid to each of the subcontractors as part of the contract (use additional pages if necessary).

John A. Everhart  
**Name of Authorized Official of Bidder**

Brandywine Construction Co., Inc.  
**Company**

Vice President  
**Title**

April 21st, 2015  
**Date**

**Contractor/Subcontractor  
Responsibility Certification**

**Contractors:**

The City of Wilmington Division of Procurement and Records must receive this executed form not later than at the time of bid submission. It may be submitted prior to bid submission for review.

**Subcontractors:**

Must submit this form to requesting contractor.

**CONTRACTOR/SUBCONTRACTOR RESPONSIBILITY CERTIFICATION  
FOR DEPARTMENT OF PUBLIC WORKS CONTRACTS  
VALUED AT MORE THAN \$100,000**

Name of Company: Brandywine Construction Company, Inc.

Address: 101 Pigeon Point Road

New Castle, DE 19720

Contract/Project Name: Sewer Maintenance

Contract Number: 16010PW

As a condition of performing "City work" (all building or construction work or projects of any kind or nature as provided in City Code Sec. 2-651) for the City of Wilmington, Delaware, contractors and subcontractors (hereinafter referred to as "Bidders") must meet certain responsible contractor requirements and qualifications specified in the Wilmington City Code, Chapter 2, Article VI, Division 6, Subdivision III (Sec. 2-561 et seq.). Pursuant thereto, the Company named above certifies the following:

**PLEASE INITIAL EACH ITEM TO INDICATE COMPLIANCE  
(Xs and check marks are *not* acceptable)**

*JAS* 1. The Bidder and its employees have all valid, effective licenses, registrations, or certificates required by federal, state, county, or local law, including, but not limited to, licenses, registrations, or certificates required to:

- a. do business in the City of Wilmington and the State of Delaware; and
- b. perform the contract work, including, but not limited to, licenses, registrations or certificates for any type of construction or maintenance trade work or specialty work which the Bidder proposes to self-perform.

*JAS* 2. The Bidder meets all:

- a. bonding requirements as required by the applicable law or contract specifications; and
- b. insurance requirements per applicable law or contract specifications, including general liability insurance, workers' compensation insurance, and unemployment insurance.

*JAS* 3. The Bidder has a satisfactory record of integrity in accordance with Sec. 2-537(4) of the City Code, which further states as follows:

The following provisions, while not exclusive, shall be sufficient to justify a finding of nonresponsibility:

- a. failure to pay taxes and fees due and owing to the City;
- b. a conviction of the contractor or a principal officer thereof for commission of a criminal offense, as incident to obtaining or attempting to obtain a public contract or in the performance of such contract;
- c. a conviction, of the contractor or principal officer thereof, under state or federal statutes, for embezzlement, theft, forgery, bribery, falsification or destruction of records, receiving stolen property, or any other offense indicating a lack of business integrity or business honesty which currently, seriously and directly affects responsibility as a city contractor.

*JAS* 4. The Bidder has a satisfactory record of timely performance of City contracts in accordance with Sec. 2-537(3) of the City Code, which further states as follows:

Contractors who are seriously deficient in current contract performance, when the number of contracts and the extent of deficiency of each are considered, shall, in the absence of evidence to the contrary or circumstances properly beyond the control of the contractor, be presumed to be unable to meet this requirement. Past unsatisfactory performance due to failure to apply necessary

tenacity, or perseverance to do an acceptable job, shall be sufficient to justify a finding of nonresponsibility.

*JAE* 5. The Bidder has a satisfactory record of performance of contractual provisions in accordance with Sec. 2-537(5) of the City Code, which further states as follows:

Violation of contract provisions of a character which justify a finding of nonresponsibility include:

- a. deliberate failure without good cause to perform in accordance with the specifications provided in the contract;
- b. a recent record of failure to perform or of unsatisfactory performance in accordance with the terms of one or more contracts;
- c. in particular, failure to comply with prevailing wage and related federal, state, and city requirements;

provided, however, that failure to perform or unsatisfactory performance caused by acts beyond the control of the contractor shall not be considered to be a basis for a finding of nonresponsibility.

*JAE* 6. The Bidder has a satisfactory record of good faith efforts to achieve disadvantaged business enterprise participation in accordance with Sec. 2-537(8) of the City Code.

*JAE* 7. The Bidder has not been debarred or suspended by any federal, state or local government agency or authority in the past three years.

*JAE* 8. The Bidder has not defaulted on any project in the past three years.

*JAE* 9. The Bidder has not had any type of business, contracting or trade license, registration, or other certification revoked or suspended in the past three years.

*JAE* 10. The Bidder and its owners have not been convicted of any crime relating to the contracting business in the past ten years.

*JAE* 11. The Bidder has not at any time been found in violation of any federal, state or local prevailing wage law.

*JAE* 12. The Bidder has not within the past three years been found in violation of any law applicable to its contracting business, including, but not limited to, licensing laws, tax laws, prompt payment laws, wage and hour laws, environmental laws or others; where the result of such violation was the payment

of a fine, back pay damages or any other type of penalty in the amount of \$1,000 or more.

*JAE* 13. The Bidder will pay all craft employees that it employs on the project the current wage rates and fringe benefits as required under applicable federal, state or local wage laws.

*JAE* 14. All craft labor that will be employed by the Bidder for the project have completed at least the OSHA 10 hour training course for safety established by the U. S. Department of Labor, Occupational Safety & Health Administration.

*JAE* 15. The Bidder will employ craft employees in all classifications and individual trades required to successfully perform the work related to the project.

*JAE* 16. The Bidder has participated in a Class A Apprenticeship Program for the past twelve months, at a minimum, for each separate trade or classification in which it employs craft employees and shall continue to participate in such program or programs for the duration of the project. The twelve month participation requirement may be waived during the first year of implementation of this Ordinance, provided that the firm is participating in a Class A Apprenticeship Program at the time it submits its bid and submits information showing that the construction craft workers it plans to use have adequate skills to successfully perform the project. Once the Ordinance has been in effect for twelve months, i.e., September 4, 2013, a waiver of this requirement will no longer be available.

- a. for purposes of this section, a Class A Apprenticeship Program is an apprenticeship program that is currently registered with and approved by the U.S. Department of Labor or a state apprenticeship agency and has graduated apprentices to journeyman status for at least three of the past five years;
- b. to ensure compliance with this section, the Bidder shall provide, with this certification, a list of all trades or classifications of craft employees it will employ on the project and documentation verifying it participates in a Class A Apprenticeship Program for each trade or classification listed;
- c. in order to enhance the training of its workforce and to comply with this subsection, the firm must enroll a new person in a Class A Apprenticeship Program for each bid submitted to the City.

*JAE* 17. The Bidder shall make all reasonable best efforts to ensure that fifteen percent (15%) of the workforce hired for the project, especially with respect to new workers recruited and hired for the project, includes City of Wilmington residents. To ensure compliance with this section, the Bidder will also make residency information on its workforce available to the City upon request.

*JAE* 18. The Bidder has all other technical qualifications and resources, including equipment, personnel and financial resources, to perform the referenced contract, or will obtain same through the use of qualified, responsible contractors.

*JAE* 19. The Bidder acknowledges that within seven (7) calendar days following the date of receipt of Notice of Intent to Award Contract, it will provide a list of subcontractors it plans to utilize for services in the performance of the contract. The list must include a brief description of the subcontractor's scope of work. In addition, each subcontractor providing services equaling or exceeding \$100,000 must provide executed Subcontractor Responsibility Certifications containing information equivalent to that required for the Bidder in the Contractor Responsibility Certification. Note: Bidder must initial this item regardless of the value of the subcontract services.

*JAE* 20. If at any time during the past five (5) years the Bidder has controlled or has been controlled by another corporation, partnership or other business entity operating in the construction industry, it will disclose such facts by attaching a detailed statement to its Contractor Responsibility Certification explaining the nature of the relationship.

*JAE* 21. The Bidder acknowledges that it shall be required to provide appropriate documentation of the conditions specified in this Contractor/Subcontractor Responsibility Certification. The Bidder also understands that the City of Wilmington may request additional information or documents at any time as the City of Wilmington deems necessary to evaluate the responsibility of Bidder. Bidder agrees to provide such additional information or supporting documentation for this Certification.

*JAE* 22. If a Bidder fails to provide the Contractor Responsibility Certification required by this section, the Bidder shall be disqualified from bidding the contract. If a Bidder fails to provide other information or documentation required by the City of Wilmington, it may be disqualified from being awarded the contract.

*JAE* 23. The Bidder shall notify the City within seven days of any material changes to all matters attested to in this certification.

Under the penalty of perjury, the Bidder's authorized representative hereby certifies that all information included in the Contractor Responsibility Certification or otherwise submitted for purposes of determining the Bidder's status as a responsible contractor is true, complete and accurate and that he/she has knowledge and authority to verify the information in this certification or otherwise submitted on behalf of the Bidder by his or her signature below.

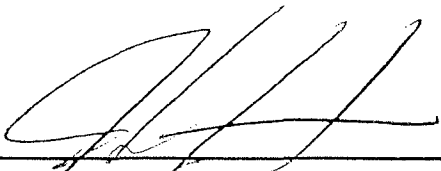
  
\_\_\_\_\_  
Authorized Signature

4/21/15  
\_\_\_\_\_  
Date

John A. Everhart  
\_\_\_\_\_  
Print Name

Vice President  
\_\_\_\_\_  
Title

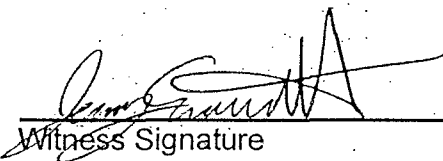
  
\_\_\_\_\_  
Witness Signature

4/21/15  
\_\_\_\_\_  
Date

PLEASE SUBMIT **SIGNED ORIGINAL** VERSION OF THIS FORM TO:

**CITY OF WILMINGTON  
DEPARTMENT OF FINANCE, DIVISION OF PROCUREMENT  
LOUIS REDDING CITY COUNTY BUILDING  
800 N. FRENCH STREET, 5<sup>TH</sup> FLOOR  
WILMINGTON, DE019801**

Questions regarding the this form can be sent to  
[procurement@wilmingtonde.gov](mailto:procurement@wilmingtonde.gov) or call 302.576.2423



City of Wilmington  
Delaware



DEPARTMENT OF PUBLIC WORKS

MEMORANDUM

**TO:** Gary Fullman  
Manager of Procurement & Records

**FROM:** Michelle K. Devillers *MKD*  
Civil Engineer II

**RE:** Contract No. 16010PW- Sewer Construction

**DATE:** May 27, 2015

The bids received for the above-referenced contract are as follows:

<u>Firm</u>	<u>Amount</u>
Brandywine Construction Co., Inc.	\$998,090.00
Joseph T. Hardy & Son, Inc.	\$1,017,670.00

Based upon review of the bids, it is recommended that we award the contract to the apparent low-bidder Brandywine Construction Co., Inc. for \$998,090.00.

APPROVED

*Jeffrey J. Starkey*  
Jeffrey J. Starkey  
Commissioner of Public Works

APPROVED

*Denita Thomas*  
Denita Thomas  
DBE Compliance Officer

Cc: Philip Ceresini, Finance- Procurement & Records  
File

**CERTIFICATE OF AWARD OF CONTRACT**

I hereby certify that Contract No. 16010PW is on this 11<sup>th</sup> day of June 2015 awarded to Brandywine Construction Co., Inc (BCCI) in the amount of \$998,090.00 as per Proposal dated 4/21/15 and that this award is made in compliance with Wilm. Code (Charter), Section 8-200, to wit:

1. Plans and specifications for the work, supplies, or materials were filed with the Department of Finance, Division of Procurement and Records for public inspection on 3/24/15
2. The advertisement calling for sealed bids on this contract was published in the News Journal on 3/24/15 & 3/31/15 stated that bids would be opened at 3:00 p. m. on 4/21/15
3. All sealed bids received were publicly opened in the office of the Department of Finance, Division of Procurement and Records in the presence of the City Auditor desiring to make the purchase at 3:00 p.m. on 4/21/15. Other persons present at the opening of the bids were: Tina Romano-Austin, Brian, Philip Ceresini
4. Bids were submitted by the following contractors in the following amounts:

<b>Contractor</b>	<b>Address</b>	<b>Date of Bid</b>	<b>Amount</b>
1. Brandywine Construction	Wilmington, DE	4.21.15	\$ 998,090.00
2. Joseph T. Hardy & Son, Inc	Wilmington, DE	4.21.15	\$1,017,670.00

5. City License Number \_\_\_\_\_

6. Upon recommendation of Commissioner of Public Works Department and after due consideration, I determined that the contractor to whom this award is made was the lowest responsible bidder. In support of this determination I have received the following written recommendations, which are on file at my office:

<u>Author</u>	<u>Employment Position</u>	<u>Date</u>
<u>Jeffrey Starkey</u>	<u>Commissioner of Public Works</u>	<u>5/27/15</u>
<u>Michelle K. Devillers</u>	<u>Civil Engineer II</u>	<u>5/27/15</u>

Approved as to Form

\_\_\_\_\_  
First Assistant City Solicitor

  
\_\_\_\_\_  
Department of Finance, Division of Procurement

# Delaware

PAGE 1

*The First State*

I, JEFFREY W. BULLOCK, SECRETARY OF STATE OF THE STATE OF DELAWARE, DO HEREBY CERTIFY "BRANDYWINE CONSTRUCTION CO., INC." IS DULY INCORPORATED UNDER THE LAWS OF THE STATE OF DELAWARE AND IS IN GOOD STANDING AND HAS A LEGAL CORPORATE EXISTENCE SO FAR AS THE RECORDS OF THIS OFFICE SHOW, AS OF THE SEVENTH DAY OF AUGUST, A.D. 2013.



0510018 8300

130943634

You may verify this certificate online  
at [corp.delaware.gov/authver.shtml](http://corp.delaware.gov/authver.shtml)

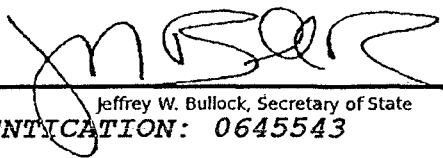
  
Jeffrey W. Bullock, Secretary of State  
AUTHENTICATION: 0645543

DATE: 08-07-13

**BRANDYWINE CONSTRUCTION CO., INC.****CERTIFIED COPY OF RESOLUTIONS**

I, the undersigned, Assistant Secretary of Brandywine Construction Co., Inc., a Delaware Corporation, hereby certify that the following Resolutions excerpted from the Minutes of the Corporation were duly adopted by unanimous consent of the Board of Directors of the Corporation on April 30<sup>th</sup>, 2015.

Resolved, that the President or Vice President of this Corporation be and he hereby is authorized to execute and deliver on behalf of this Corporation a contract and other contract documents by and between this Corporation and The City of Wilmington, Delaware, Department of Finance, **Contract #16010PW – “Sewer Construction”** for the Contract Price of **\$998,090.00** and it was

FURTHER RESOLVED, that the Secretary and Assistant Secretary of this Corporation be and (he or she) hereby is authorized to attest to the said contract and other documents.

I further certify that the foregoing Resolutions have not been rescinded or modified and remain in full force and effect.

I further certify that the following are the names of all Officers qualified to sign for the Corporation

PRESIDENT	<u>John R. Doherty</u>
VICE PRESIDENT	<u>John A. Everhart</u>
SECRETARY	<u>John A. Everhart</u>
ASST. SECRETARY	<u>Vickie L. Buckalew</u>

IN WITNESS WHEREOF, I have hereunto set my hand and the seal of the Corporation this 23<sup>rd</sup> day of June, 2015 AD

Vickie L. Buckalew  
Vickie L. Buckalew, Assistant Secretary

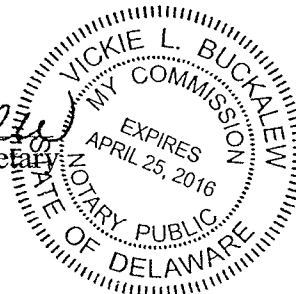

--- - - C O N T R A C T-----

THIS AGREEMENT, made the 23rd day of June in the year Two Thousand Fifteen by and between the City of Wilmington, a municipal corporation of the State of Delaware, acting through the agency of the Department of Finance, Division of Procurement and Records, party of the first part (hereinafter designated the (Owner), and Brandywine Construction Company, Inc (BCCI) of the second part (hereinafter designated the (Contractor)

WITNESSETH, that the Contractor, in consideration of agreements herein made by the Owner, agrees with the Owner as follows:

Article 1. The Contractor shall and will furnish and deliver per specifications, on contract 16010PW "Sewer Construction" for the Department of Public Works in accordance with Advertisement for Bids by the Department of Finance, Division of Procurement and Records date 3/24/15 & 3/31/15 and specifications identified as Contract No. 16010PW and by the signatures of the parties hereto, are, together with the said Advertisement for Bids, Instructions to Bidders, Forms of Proposal and Bond, and/or other documents pertinent thereto, hereby acknowledge and incorporated into these presents and are to be taken as a part of this Contract.

Article 2. It is understood and agreed by and between the parties hereto that the amount of this Contract is in the amount of Nine Hundred Ninety Eight Thousand Ninety --- 00/100 ----- ---Dollars (\$998,090.00) as per Proposal dated 4/21/15 to the Department of Finance, Division of Procurement and Records.

Article 3. In the performance of this Contract, the Contractor shall not discriminate or permit discrimination against any person because of his race, color, religion or his national origin.

Article 4. This Agreement shall bind the heirs, executors, administrators, successors and assigns to the respective parties hereto.

In witness whereof the party of the first part has, by recommendation of the Commissioner of Public Works Department, caused the hand of Dennis P. Williams, Mayor, and the corporate seal of the City of Wilmington, attested by the City Clerk, to be hereunto affixed; and the party of the second part has caused the hand of its' President, (or his authorized representative) and its' corporate seal, attested by the Secretary or assistant Secretary, to be hereunto affixed.

Dated the day and year first above written in the City of Wilmington, County of New Castle, State of Delaware.

Signed, Sealed and delivered  
in the presence of:

THE CITY OF WILMINGTON

Witness

By: Dennis P. Williams, Mayor

ATTEST:

City Clerk

*Vickie L. Buckalew*  
Witness

Brandywine Construction Co., Inc.

By: *John R. Doherty*  
President (Seal)

ATTEST:

*[Signature]*  
Secretary

Approved as to form on this \_\_\_\_\_

Day of \_\_\_\_\_, 2015

\_\_\_\_\_  
First Assistant City Solicitor